

# YOUFOUND PRECISION CO. LTD.



**YOUFOUND 裕丰**  
YOUFOUND PRECISION

YOUFOUND PRECISION CO. LTD.

浙江长兴裕丰精密机械有限公司

358 Luyin Ave, Sian Industrial Park, Changxing, Zhejiang, China 313113

浙江省 长兴县泗安工业区绿荫大道358号 313113

Tel: +86 572 6822951/2/3/4

Fax: +86 572 6822955

Email: [master@youfoundtools.com](mailto:master@youfoundtools.com)

Http://[www.youfoundtools.com](http://www.youfoundtools.com)

**YOUFOUND 裕丰**  
YOUFOUND PRECISION

### 裕丰概

浙江长兴裕丰精密机械有限公司（前身杭州裕丰工量具制造有限公司）是一家高新技术企业，现占地面积26660平方米，建筑面积12000平方米，拥有员工200多人，其中专业技术质管人员30人。公司拥有自营进出口权和欧盟"ROSH"环保认证及"CE"安全认证。裕丰精密机械有限公司自2000年成立以来不断创新进取，迅速壮大，不仅在国内量具业类占据举足轻重的地位，而且也逐步将成就推向国外并在美国加州地区建立子公司和无人化管理的仓库中心。

### 裕丰产品

本公司主要生产电子数显卡尺系列产品；电子数显深度尺系列；带表卡尺系列产品以及其它各类电子数显和带表的通用及专业化非标准量具。目前公司的年生产规模已达200万套。90%以上出口到欧、美、亚、非等三十多个国家和地区。

### 裕丰理念

立志发展制造业，用心做事，不断发现和创造更先进。重视搭建信息化管理平台。充分发挥人和机器的优势来保证制造过程的有效控制和稳定。以最高的标准市场提供产品和服务。在不断提升中发展自我。

### 裕丰宗旨

"质量第一、用户至上。"以争创优质产品，完善售后服务为根本，为客户提供最完善的服务和做高性价比的产品。

### 裕丰目标

充分利用技术领先、管理科学、成本管理的优势，逐步实现"国内第一、世界一流"的战略发展目标。

### Profile

As a high-tech enterprise, Zhejiang Changxing Youfound Precision Machinery Co., Ltd. (formerly known as Hangzhou Youfound Measuring Tool Manufacturing Co., Ltd.) now covers an area of 26,660 m<sup>2</sup> including a building area of 12,000 m<sup>2</sup>, and has more than 200 employees including 30 professional technical quality control personnel. It has self-support import and export rights and has passed EU "ROSH" environmental certification and "CE" safety certification. Founded in 2000, Youfound Precision Machinery Co., Ltd. has constantly innovated, made progresses and grown stronger rapidly, which not only gradually takes a decisive position in the measuring tool industry of China but also gradually promotes achievements to foreign countries and has established a subsidiary and an unattended warehouse center in California.

### Products

The company mainly produces electronic digital caliper series products, electronic digital depth gauge series products, dial caliper series products and other various electronic digital and dial general and professional non-standard measuring tools, with the current annual production scale of 2 million sets in which over 90% are exported to more than thirty countries and regions such as Europe, America, Asia and Africa.

### Philosophy

Be determined to develop the manufacturing industry, do intentions, and constantly discover and innovate for future advancement. Attach importance to set up an information management platform. Give full play to the advantages of human and machinery, to ensure the effective control and stabilization of manufacturing processes. Provide products and services for the market at the highest standard. Develop ourselves in constant improvement.

### Tenet

"Quality First, Customer Supreme." Provide customers with the best service and make products with high cost performance on the basis of striving to create high-quality products and perfecting after-sales service.

### Objective

Make full use of the advantages of technology leadership, management science and cost management, to gradually achieve the strategic development goal of "Domestic First, World Class".





》用科技精神 衡量世界价值

精益求精  
角度的执着  
尺度的严谨  
尺寸在不停增长，精度也是。



## 目录 CATALOG

数显卡尺 ELECTRONIC DIGITAL CALIPER	01 - 14	
带表卡尺 DIAL CALIPER	15 - 16	
游标卡尺 VERNIER CALIPER	17 - 26	
数显深度尺 DIGITAL DEPTH GAUGE	27 - 34	
特殊卡尺 SPECIAL CALIPER	35 - 46	
车用卡尺 AUTOMOTIVE CALIPER	47 - 52	
千分尺 MICROMETER	53 - 54	
百分表 DIAL	55 - 58	
数显标尺 DIGITAL SCALE UNIT	59 - 62	
外接显示器, 数据输出 EXTERNAL DISPLAY, DATA OUTPUT	63 - 65	

● **SELF-LUMINOUS DIGITAL CALIPER**  
自发光背光电子数显卡尺

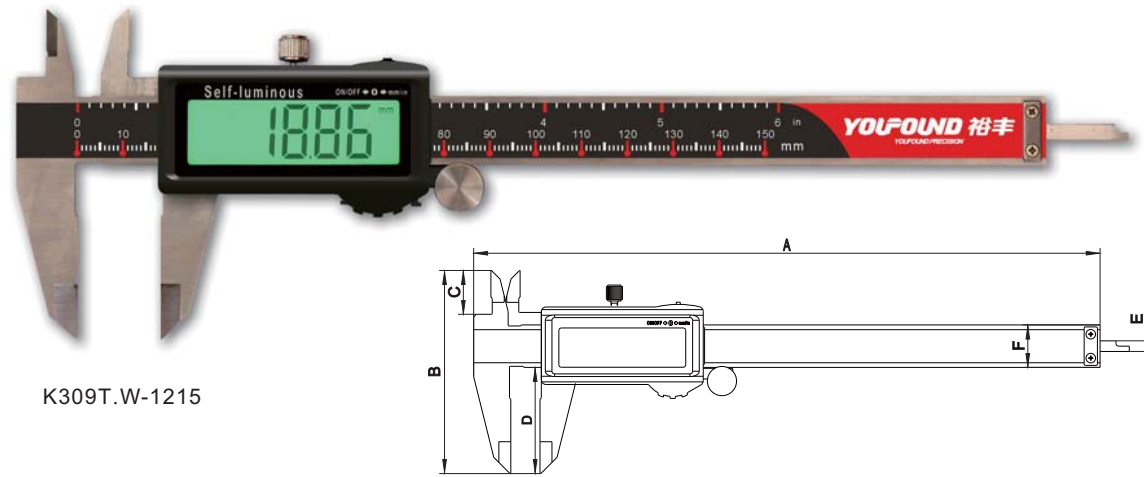

K309T.W-1215

● **Features 特性**

- Din 862**  
DIN862标准
  - 12mm**  
Number size 12mm 12mm字高
  - 0**  
Arbitrary set zero 任意位置置零
  - mm In**  
MM-IN 公英制转换
  - 3**  
Max moving speed 3m/s 最大移动速度 3米/秒
  - Stainless Hardened**  
不锈钢淬硬
  - Self luminous**  
自发光背光
  - Ergonomics**  
人体工程学设计
  - Patent**  
专利产品
- 
- Outside**  
外测量面
  - Inside**  
内测量面
  - Depth**  
深度测量面
  - Step**  
台阶测量面

● **Optional features 可选功能**

- Pointed jaw**  
细尖爪
- Mini inner jaw**  
细窄内量
- Rod depth gauge**  
圆深度杆
- Without Roller wheel**  
无滚轮
- Ti**  
表面镀钛
- Auto off**  
自动断电 可选

	Specification 规格	QTY/CTN 装箱数量	N. W. /G. W. 净重/毛重 (kg)	Meas(cm) 外箱尺寸	A	B	C	D	E	F
K309T.W-1210	0-100mm*0.01/0-4in*0.0005	50	14.5/17.1	51.3*26.8*32	185	76.5	16.5	40	4	16
K309T.W-1215	0-150mm*0.01/0-6in*0.0005	50	15.2/17.8	51.3*26.8*32	236	76.5	16.5	40	4	16
K309T.W-1220	0-200mm*0.01/0-8in*0.0005	50	18.6/22.9	61.8*34.6*32.9	290	90	19.7	50	4	16
K309T.W-1230	0-300mm*0.01/0-12in*0.0005	20	12.9/15.9	46.3*30.4*36.2	390	105	22.7	62	4	16

● **FULL-SCREEN DISPLAY Ip54 DIGITAL CALIPER**  
全屏Ip54防护电子数显卡尺

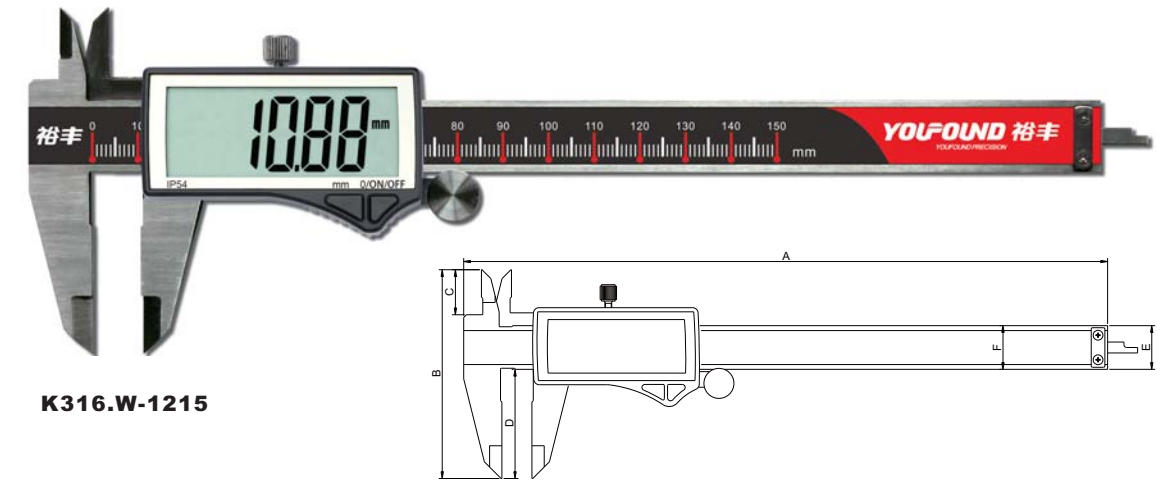

K316.W-1215

● **Features 特性**

- Din 862**  
DIN862标准
  - Ip54**  
Ip54防护
  - 0**  
Arbitrary set zero 任意位置置零
  - mm In**  
MM-IN 公英制转换
  - 1.5**  
Max moving speed 1.5m/s 最大移动速度 1.5米/秒
  - Stainless Hardened**  
不锈钢淬硬
  - Full-screen display**  
全屏显示
  - Ergonomics**  
人体工程学设计
  - Patent**  
专利产品
- 
- Outside**  
外测量面
  - Inside**  
内测量面
  - Depth**  
深度测量面
  - Step**  
台阶测量面

● **Optional features 可选功能**

- Pointed jaw**  
细尖爪
- Mini inner jaw**  
细窄内量
- Rod depth gauge**  
圆深度杆
- Ti**  
表面镀钛
- USB**  
USB 模式接口
- 3**  
Max moving speed 3m/s 最大移动速度 3米/秒
- Auto off**  
自动断电 可选
- mm**  
单公制
- fraction**  
英制分数显示

	Specification 规格	QTY/CTN 装箱数量	N. W. /G. W. 净重/毛重 (kg)	Meas(cm) 外箱尺寸	A	B	C	D	E	F
K316-1210	0-100mm*0.01/0-4in*0.0005	50	14.5/17.1	51.3*26.8*32	185	76.5	16.5	40	4	16
K316-1215	0-150mm*0.01/0-6in*0.0005	50	15.2/17.8	51.3*26.8*32	236	76.5	16.5	40	4	16
K316-1220	0-200mm*0.01/0-8in*0.0005	50	18.6/22.9	61.8*34.6*32.9	290	90	19.7	50	4	16
K316-1230	0-300mm*0.01/0-12in*0.0005	20	12.9/15.9	46.3*30.4*36.2	390	105	22.7	62	4	16

● **Ip67 DIGITAL CALIPER**  
Ip67防护电子数显卡尺

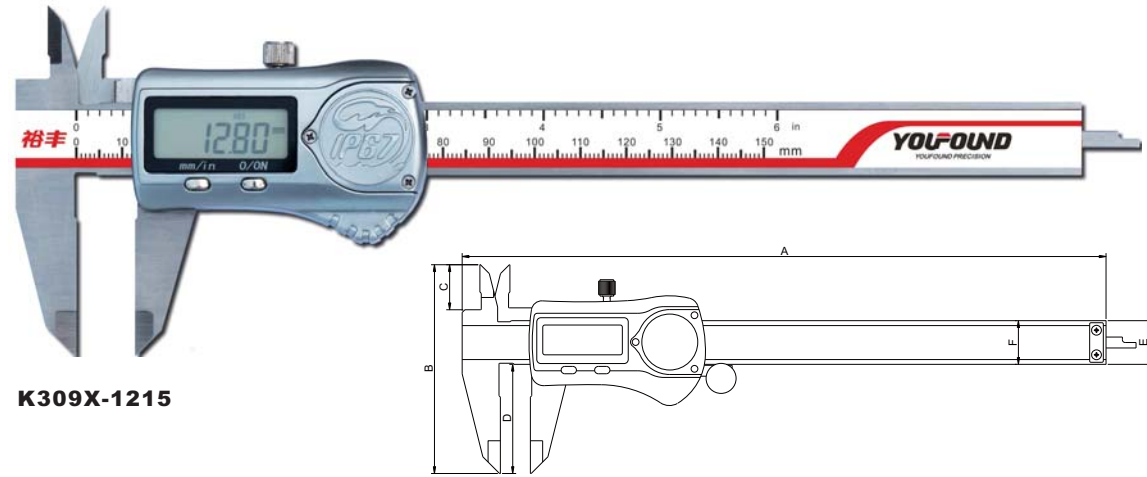

**K309X-1215**

● **Features 特性**

- DIN 862**  
DIN862  
DIN862标准
- Metal casing**  
金属罩壳
- MM only**  
单公制
- Ip67**  
Ip67防护
- Arbitrary set zero**  
任意位置  
置零
- Stainless Hardened**  
不锈钢淬硬
- Outside**  
外测量面
- Inside**  
内测量面
- Depth**  
深度测量面
- Step**  
台阶测量面

● **Optional features 可选功能**

- Pointed jaw**  
细尖爪
- Mini inner jaw**  
细窄内量
- Rod depth gauge**  
圆深度杆
- Without Roller wheel**  
无滚轮
- Titanize**  
表面镀钛
- Auto off**  
自动断电  
可选

	Specification 规格	QTY/CTN 装箱数量	N. W. /G. W. 净重/毛重(kg)	Meas(cm) 外箱尺寸	A	B	C	D	E	F
K309X-1210M	0-100mm*0.01	50	14.5/17.1	51.3*26.8*32	185	76.5	16.5	40	4	16
K309X-1215M	0-150mm*0.01	50	15.2/17.8	51.3*26.8*32	236	76.5	16.5	40	4	16
K309X-1220M	0-200mm*0.01	50	18.6/22.9	61.8*34.6*32.9	290	90	19.7	50	4	16
K309X-1230M	0-300mm*0.01	20	12.9/15.9	46.3*30.4*36.2	390	105	22.7	62	4	16

● **3-KEY DIGITAL CALIPER WITH LARGE SCREEN**  
3按键大屏电子数显卡尺

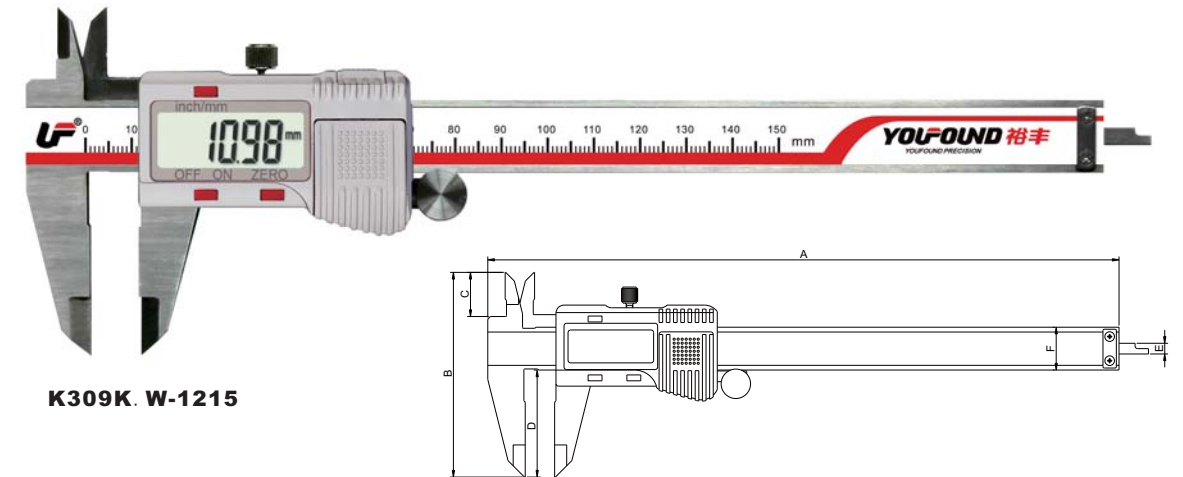

**K309K.W-1215**

● **Features 特性**

- DIN 862**  
DIN862  
DIN862标准
- 11mm**  
Number size 11mm  
11mm字高
- Arbitrary set zero**  
任意位置  
置零
- MM-IN**  
公英制转换
- 1.5**  
Max moving speed 1.5m/s  
最大移动速度  
1.5米/秒
- Stainless Hardened**  
不锈钢淬硬
- Outside**  
外测量面
- Inside**  
内测量面
- Depth**  
深度测量面
- Step**  
台阶测量面

● **Optional features 可选功能**

- Pointed jaw**  
细尖爪
- Mini inner jaw**  
细窄内量
- Rod depth gauge**  
圆深度杆
- Without Roller wheel**  
无滚轮
- Titanize**  
表面镀钛
- USB**  
USB  
模式接口
- 3**  
Max moving speed 3m/s  
最大移动速度  
3米/秒
- Auto off**  
自动断电  
可选

● **Optional calipers 可选款式**



	Specification 规格	QTY/CTN 装箱数量	N. W. /G. W. 净重/毛重(kg)	Meas(cm) 外箱尺寸	A	B	C	D	E	F
K309K.W-1210	0-100mm*0.01/0-4in*0.0005	50	14.5/17.1	51.3*26.8*32	185	76.5	16.5	40	4	16
K309K.W-1215	0-150mm*0.01/0-6in*0.0005	50	15.2/17.8	51.3*26.8*32	236	76.5	16.5	40	4	16
K309K.W-1220	0-200mm*0.01/0-8in*0.0005	50	18.6/22.9	61.8*34.6*32.9	290	90	19.7	50	4	16
K309K.W-1230	0-300mm*0.01/0-12in*0.0005	20	12.9/15.9	46.3*30.4*36.2	390	105	22.7	62	4	16

● **METAL CASING DIGITAL CALIPER**  
金属罩壳电子数显卡尺

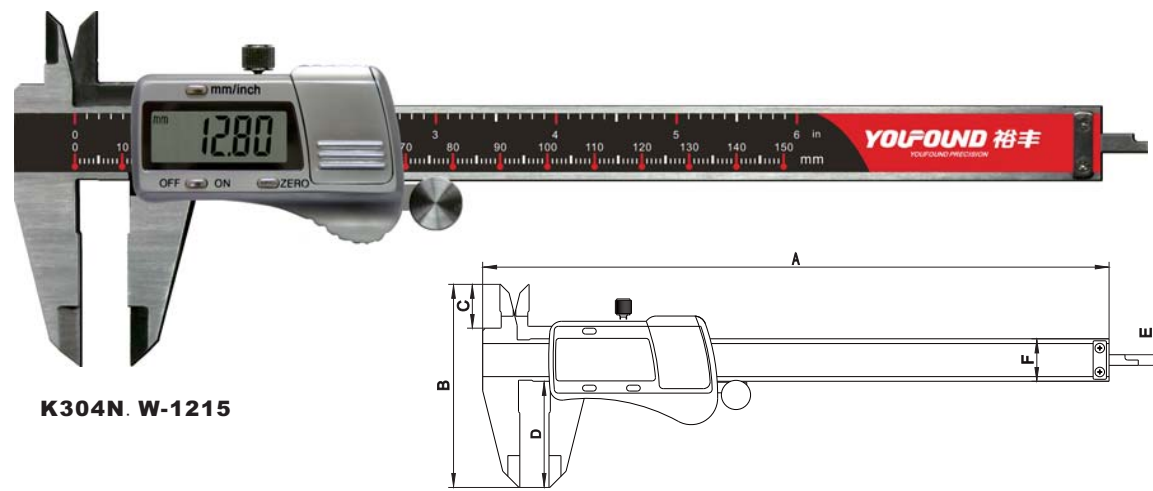

**K304N.W-1215**

● Features 特性



● Optional features 可选功能



● Optional calipers 可选款式



	Specification 规格	QTY/CTN 装箱数量	N. W. /G. W. 净重/毛重 (kg)	Meas(cm) 外箱尺寸	A	B	C	D	E	F
K304N.W-1210	0-100mm*0.01/0-4in*0.0005	50	14.5/17.1	51.3*26.8*32	185	76.5	16.5	40	4	16
K304N.W-1215	0-150mm*0.01/0-6in*0.0005	50	15.2/17.8	51.3*26.8*32	236	76.5	16.5	40	4	16
K304N.W-1220	0-200mm*0.01/0-8in*0.0005	50	18.6/22.9	61.8*34.6*32.9	290	90	19.7	50	4	16
K304N.W-1230	0-300mm*0.01/0-12in*0.0005	20	12.9/15.9	46.3*30.4*36.2	390	105	22.7	62	4	16

● **Ip54 DIGITAL CALIPER**  
Ip54防护电子数显卡尺

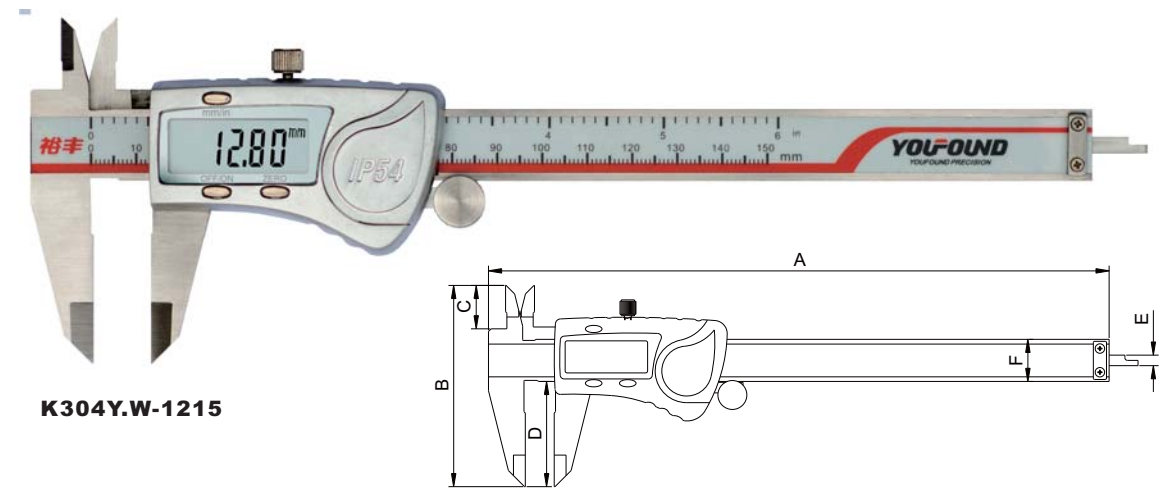

**K304Y.W-1215**

● Features 特性



● Optional features 可选功能



● Optional features 可选功能

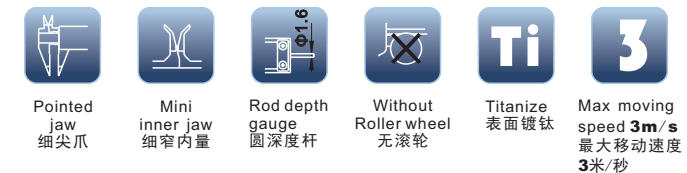

● Optional calipers 可选款式



	Specification 规格	QTY/CTN 装箱数量	N. W. /G. W. 净重/毛重 (kg)	Meas(cm) 外箱尺寸	A	B	C	D	E	F
K304Y.W-1210	0-100mm*0.01/0-4in*0.0005	50	14.5/17.1	51.3*26.8*32	185	76.5	16.5	40	4	16
K304Y.W-1215	0-150mm*0.01/0-6in*0.0005	50	15.2/17.8	51.3*26.8*32	236	76.5	16.5	40	4	16
K304Y.W-1220	0-200mm*0.01/0-8in*0.0005	50	18.6/22.9	61.8*34.6*32.9	290	90	19.7	50	4	16
K304Y.W-1230	0-300mm*0.01/0-12in*0.0005	20	12.9/15.9	46.3*30.4*36.2	390	105	22.7	62	4	16

● **3-KEY DIGITAL CALIPER WITH STANDARD SCREEN**

3按键普通屏电子数显卡尺

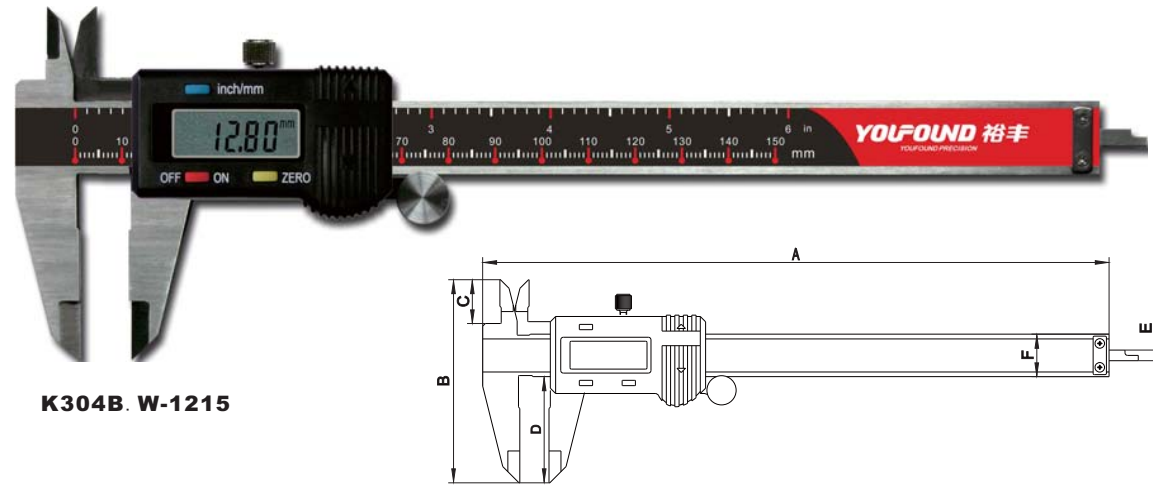

**K304B.W-1215**

● **Features 特性**



● **Optional features 可选功能**



● **Optional calipers 可选款式**



**K304F.W**

	Specification 规格	QTY/CTN 装箱数量	N. W. /G. W. 净重/毛重 (kg)	Meas(cm) 外箱尺寸	A	B	C	D	E	F
K304B.W-1210	0-100mm*0.01/0-4in*0.0005	50	14.5/17.1	51.3*26.8*32	185	76.5	16.5	40	4	16
K304B.W-1215	0-150mm*0.01/0-6in*0.0005	50	15.2/17.8	51.3*26.8*32	236	76.5	16.5	40	4	16
K304B.W-1220	0-200mm*0.01/0-8in*0.0005	50	18.6/22.9	61.8*34.6*32.9	290	90	19.7	50	4	16
K304B.W-1230	0-300mm*0.01/0-12in*0.0005	20	12.9/15.9	46.3*30.4*36.2	390	105	22.7	62	4	16

● **4-KEY DIGITAL CALIPER**

4按键电子数显卡尺

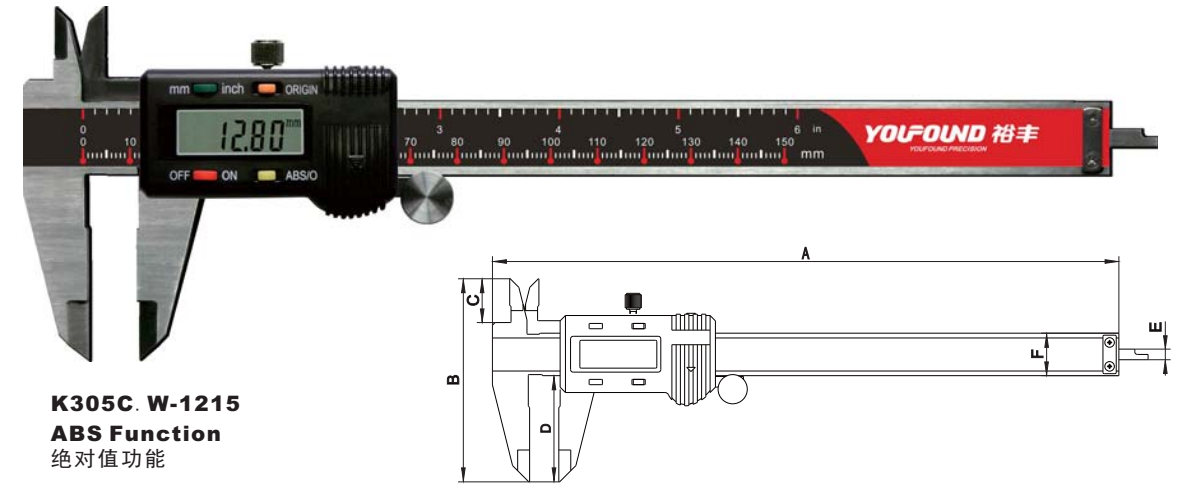

**K305C.W-1215**  
**ABS Function**  
绝对值功能

● **Features 特性**



● **Optional features 可选功能**



● **Optional calipers 可选款式**



	Specification 规格	QTY/CTN 装箱数量	N. W. /G. W. 净重/毛重 (kg)	Meas(cm) 外箱尺寸	A	B	C	D	E	F
K305C.W-1210	0-100mm*0.01/0-4in*0.0005	50	14.5/17.1	51.3*26.8*32	185	76.5	16.5	40	4	16
K305C.W-1215	0-150mm*0.01/0-6in*0.0005	50	15.2/17.8	51.3*26.8*32	236	76.5	16.5	40	4	16
K305C.W-1220	0-200mm*0.01/0-8in*0.0005	50	18.6/22.9	61.8*34.6*32.9	290	90	19.7	50	4	16
K305C.W-1230	0-300mm*0.01/0-12in*0.0005	20	12.9/15.9	46.3*30.4*36.2	390	105	22.7	62	4	16

● **FRACTION DISPLAY DIGITAL CALIPER**

英制分数显示电子数显卡尺

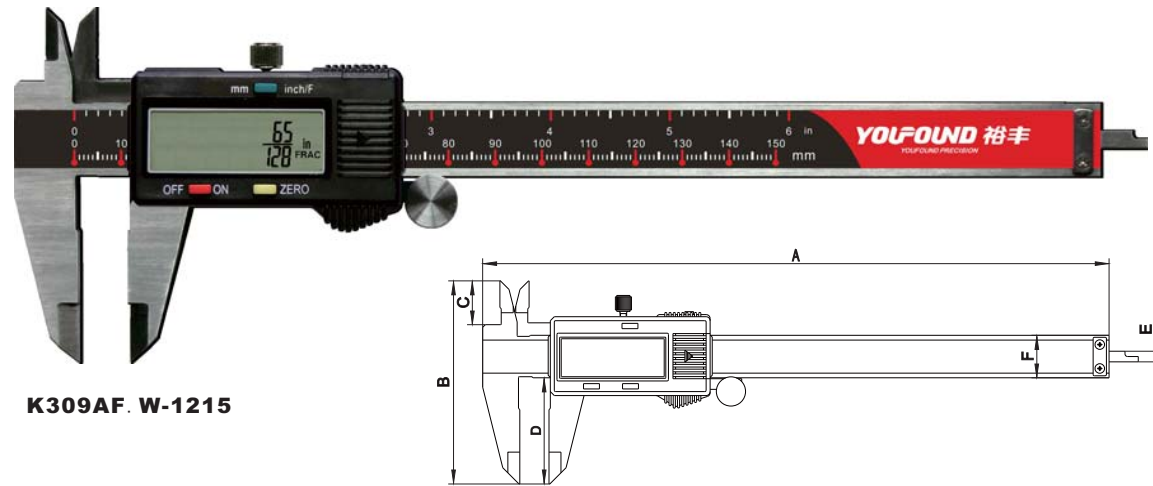

**K309AF.W-1215**

● **Features 特性**



● **Optional features 可选功能**



● **Optional calipers 可选款式**

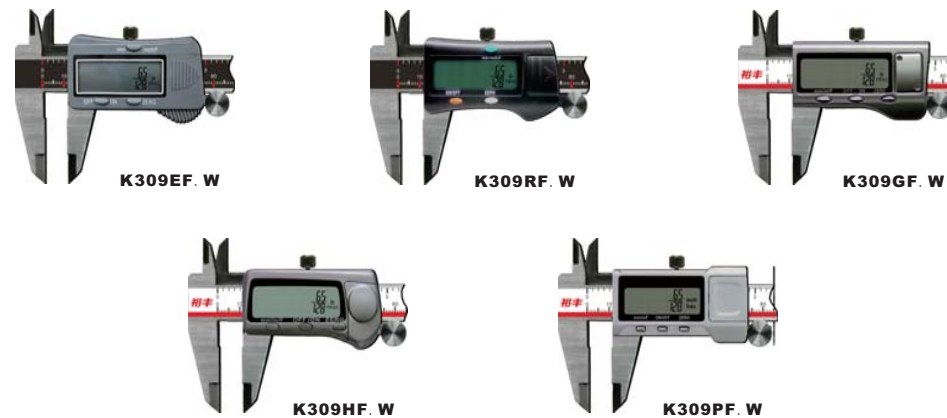

● **FRACTION DISPLAY DIGITAL CALIPER**

英制分数显示电子数显卡尺

	Specification 规格	QTY/CTN 装箱数量	N. W. /G. W. 净重/毛重(kg)	Meas(cm) 外箱尺寸	A	B	C	D	E	F
K309AF2.W-1210	0-100mm*0.01/0-4in*0.0005 /0-4in*1/128	50	14.5/17.1	51.3*26.8*32	185	76.5	16.5	40	4	16
K309AF2.W-1210	0-100mm*0.01/0-4in*0.0005 /0-4in*1/128	50	14.5/17.1	51.3*26.8*32	185	76.5	16.5	40	4	16
K309AF3.W-1210	0-100mm*0.01/0-4in*0.0005 /0-4in*1/256	50	14.5/17.1	51.3*26.8*32	185	76.5	16.5	40	4	16
K309AF4.W-1210	0-100mm*0.01/0-4in*0.0005 /0-4in*1/32	50	14.5/17.1	51.3*26.8*32	185	76.5	16.5	40	4	16
K309AF1.W-1215	0-150mm*0.01/0-6in*0.0005 /0-6in*1/64	50	15.2/17.8	51.3*26.8*32	236	76.5	16.5	40	4	16
K309AF2.W-1215	0-150mm*0.01/0-6in*0.0005 /0-6in*1/128	50	15.2/17.8	51.3*26.8*32	236	76.5	16.5	40	4	16
K309AF3.W-1215	0-150mm*0.01/0-6in*0.0005 /0-6in*1/256	50	15.2/17.8	51.3*26.8*32	236	76.5	16.5	40	4	16
K309AF4.W-1215	0-150mm*0.01/0-6in*0.0005 /0-6in*1/32	50	15.2/17.8	51.3*26.8*32	236	76.5	16.5	40	4	16
K309AF1.W-1220	0-200mm*0.01/0-8in*0.0005 /0-8in*1/64	50	18.6/22.9	61.8*34.6*32.9	290	90	19.7	50	4	16
K309AF2.W-1220	0-200mm*0.01/0-8in*0.0005 /0-8in*1/128	50	18.6/22.9	61.8*34.6*32.9	290	90	19.7	50	4	16
K309AF3.W-1220	0-200mm*0.01/0-8in*0.0005 /0-8in*1/256	50	18.6/22.9	61.8*34.6*32.9	290	90	19.7	50	4	16
K309AF4.W-1220	0-200mm*0.01/0-8in*0.0005 /0-8in*1/32	50	18.6/22.9	61.8*34.6*32.9	290	90	19.7	50	4	16
K309AF1.W-1230	0-300mm*0.01/0-12in*0.0005 /0-12in*1/64	20	12.9/15.9	46.3*30.4*36.2	390	105	22.7	62	4	16
K309AF2.W-1230	0-300mm*0.01/0-12in*0.0005 /0-12in*1/128	20	12.9/15.9	46.3*30.4*36.2	390	105	22.7	62	4	16
K309AF3.W-1230	0-300mm*0.01/0-12in*0.0005 /0-12in*1/256	20	12.9/15.9	46.3*30.4*36.2	390	105	22.7	62	4	16
K309AF4.W-1230	0-300mm*0.01/0-12in*0.0005 /0-12in*1/32	20	12.9/15.9	46.3*30.4*36.2	390	105	22.7	62	4	16

● **MM ONLY DIGITAL CALIPER**  
单公制电子数显卡尺

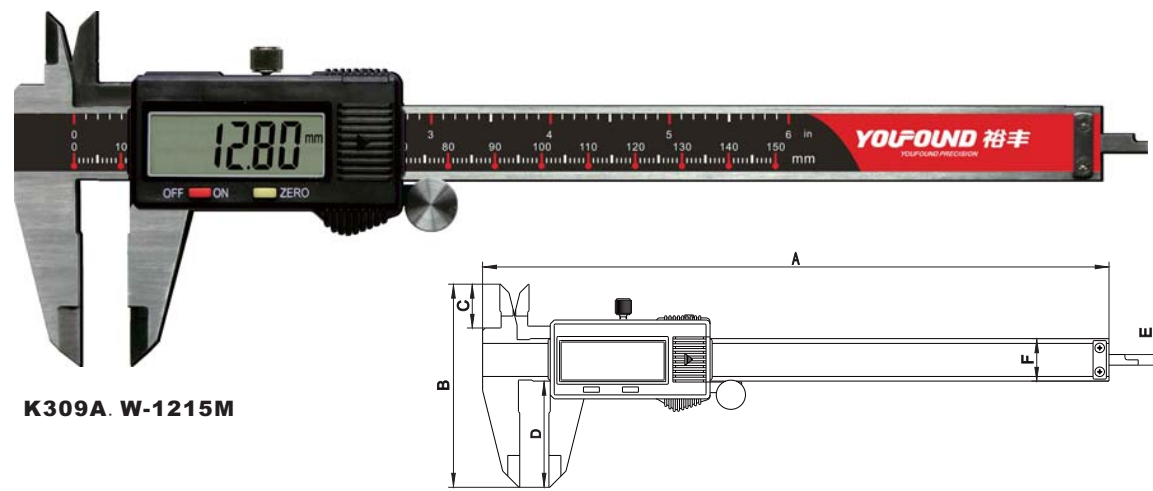

**K309A.W-1215M**

● **Features 特性**



● **Optional features 可选功能**



	Specification 规格	QTY/CTN 装箱数量	N. W. /G. W. 净重/毛重(kg)	Meas(cm) 外箱尺寸	A	B	C	D	E	F
K309A.W-1210M	0-100mm*0.01	50	14.5/17.1	51.3*26.8*32	185	76.5	16.5	40	4	16
K309A.W-1215M	0-150mm*0.01	50	15.2/17.8	51.3*26.8*32	236	76.5	16.5	40	4	16
K309A.W-1220M	0-200mm*0.01	50	18.6/22.9	61.8*34.6*32.9	290	90	19.7	50	4	16
K309A.W-1230M	0-300mm*0.01	20	12.9/15.9	46.3*30.4*36.2	390	105	22.7	62	4	16

● **LEFT HAND DIGITAL CALIPER**  
左手电子数显卡尺

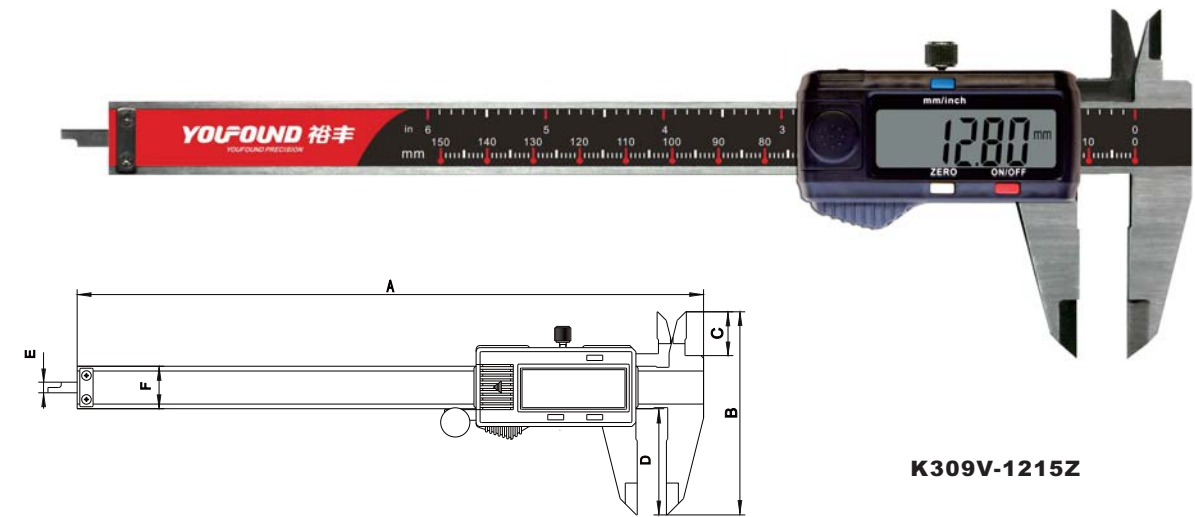

**K309V-1215Z**

● **Features 特性**



● **Optional features 可选功能**



	Specification 规格	QTY/CTN 装箱数量	N. W. /G. W. 净重/毛重(kg)	Meas(cm) 外箱尺寸	A	B	C	D	E	F
K309V-1210Z	0-100mm*0.01/0-4in*0.0005	50	14.5/17.1	51.3*26.8*32	185	76.5	16.5	40	4	16
K309V-1215Z	0-150mm*0.01/0-6in*0.0005	50	15.2/17.8	51.3*26.8*32	236	76.5	16.5	40	4	16
K309V-1220Z	0-200mm*0.01/0-8in*0.0005	50	18.6/22.9	61.8*34.6*32.9	290	90	19.7	50	4	16
K309V-1230Z	0-300mm*0.01/0-12in*0.0005	20	12.9/15.9	46.3*30.4*36.2	390	105	22.7	62	4	16

● **MINI DIGITAL CALIPER**  
迷你电子数显卡尺

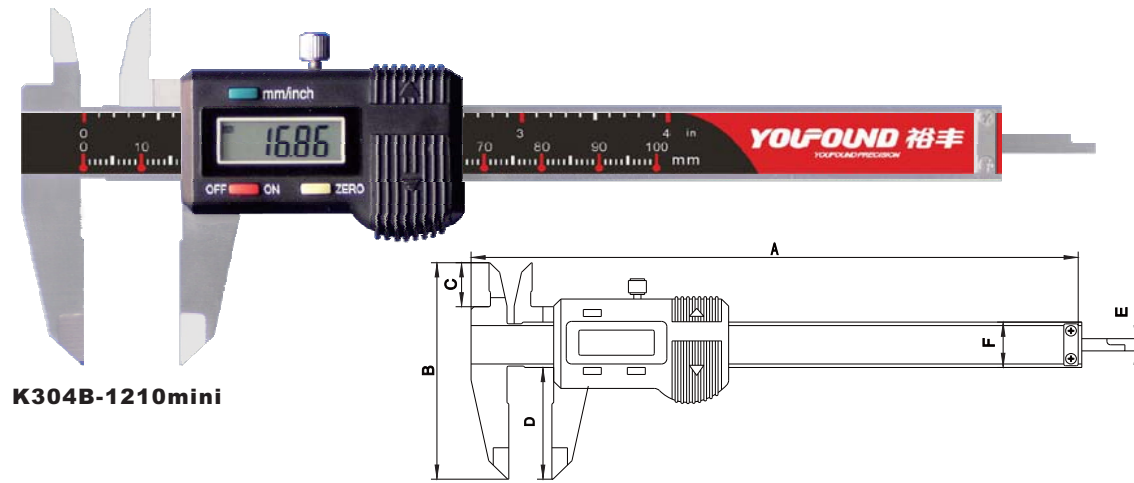

K304B-1210mini

● **Features 特性**

- Din 862**  
DIN862标准
- mini**  
mini design 迷你设计
- Arbitrary set zero**  
任意位置置零
- MM-IN**  
公英制转换
- 1.5**  
Max moving speed 1.5m/s  
最大移动速度 1.5米/秒
- Stainless Hardened**  
不锈钢淬硬
- Outside**  
外测量面
- Inside**  
内测量面
- Depth**  
深度测量面
- Step**  
台阶测量面

● **Optional features 可选功能**

- Rod depth gauge**  
圆深度杆
- Ti**  
Titanize 表面镀钛
- 3**  
Max moving speed 3m/s  
最大移动速度 3米/秒
- Auto off**  
自动断电 可选

● **Optional calipers 可选款式**



K309A-1210mini

K309G-1210mini

	Specification 规格	QTY/CTN 装箱数量	N. W. /G. W. 净重/毛重 (kg)	Meas(cm) 外箱尺寸	A	B	C	D	E	F
K304B.W-12075mini	0-75mm*0.01/0-3in*0.0005	100	17.3/20.8	42.5*40.5*32.2	145	62	12.5	32	3.5	13
K304B.W-1210mini	0-100mm*0.01/0-4in*0.0005	100	17.8/21.3	42.5*40.5*32.2	170	62	12.5	32	3.5	13

● **WORKSHOP DIGITAL CALIPER**  
IV型电子数显卡尺

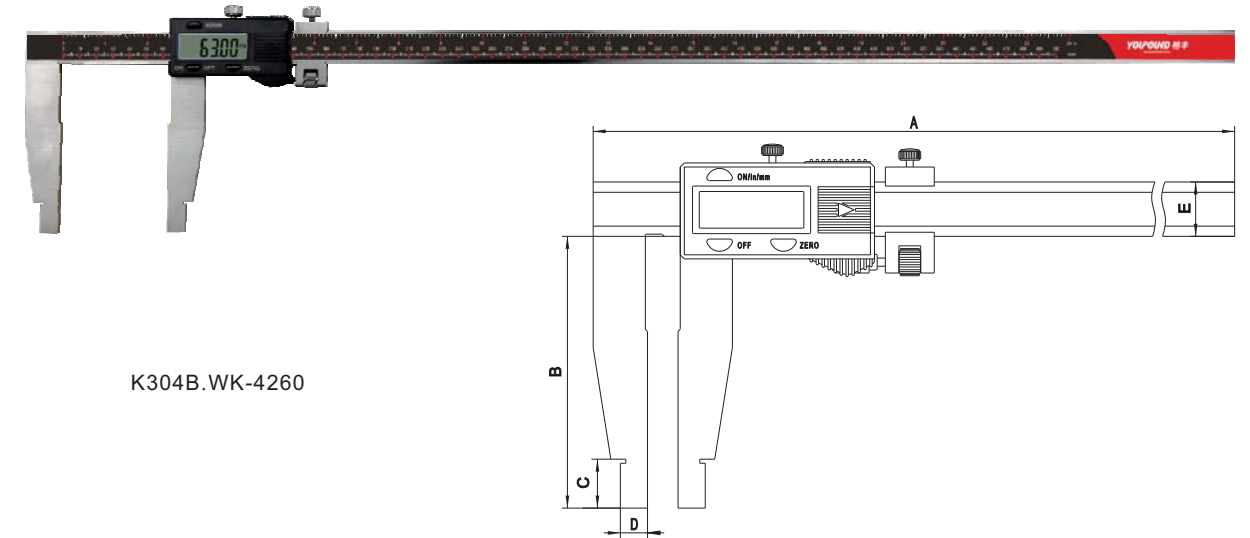

K304B.WK-4260

● **Features 特性**

- Din 862**  
DIN862标准
- 12mm**  
Number size 12mm  
12mm字高
- Arbitrary set zero**  
任意位置置零
- MM-IN**  
公英制转换
- 1.5**  
Max moving speed 1.5m/s  
最大移动速度 1.5米/秒
- Stainless Hardened**  
不锈钢淬硬
- Outside**  
外测量面
- Inside**  
内测量面

● **Optional features 可选功能**

- Length Jaws**  
加长爪
- 3**  
Max moving speed 3m/s  
最大移动速度 3米/秒

	Specification 规格	QTY/CTN 装箱数量	N. W. /G. W. 净重/毛重 (kg)	Meas(cm) 外箱尺寸	A	B	C	D	E
K304B.WK-4245	0-450mm*0.01/0-18in*0.0005	10	11.3/13.2	64.5*37.5*20.7	505	100	18	10	20
K304B.WK-4250	0-500mm*0.01/0-20in*0.0005	10	12.3/14.2	64.5*37.5*20.7	635	100	18	10	20
K304B.WK-4260	0-600mm*0.01/0-24in*0.0005	10	14.1/16.2	64.5*37.5*20.7	735	100	18	10	20

● **WHOLE SEALING DOUBLE SHOCK PROOF DIAL CALIPER**  
金属壳闭式双防震带表卡尺

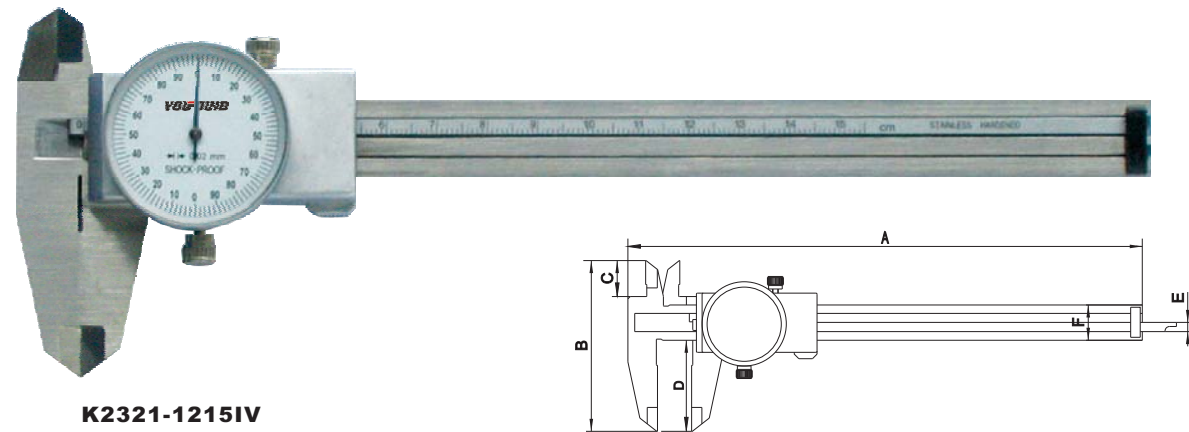

**K2321-1215IV**

● **Features 特性**

- DIN862  
DIN862标准
- Metal casing  
金属罩壳
- Double shock proof  
双向防震
- Zero set  
0位微调
- Stainless Hardened  
不锈钢淬硬
- Outside  
外测量面
- Inside  
内测量面
- Depth  
深度测量面
- Step  
台阶测量面
- Dial color optional  
表盘颜色可选

	Specification 规格	QTY/CTN 装箱数量	N. W. /G. W. 净重/毛重(kg)	Meas(cm) 外箱尺寸	A	B	C	D	E	F
K2321-1215IV	0-150mm*0.01	50	15.2/17.8	51.3*26.8*32	228	75	15.8	40	3.8	15.5
K2322-1215IV	0-150mm*0.02	50	15.2/17.8	51.3*26.8*32	228	75	15.8	40	3.8	15.5
K2323-1215IV	0-6in*0.001	50	15.2/17.8	51.3*26.8*32	228	75	15.8	40	3.8	15.5
K2321-1220IV	0-200mm*0.01	50	20.7/22	61.8*34.6*32.9	280	89	19.8	50	3.8	15.5
K2322-1220IV	0-200mm*0.02	50	20.7/22	61.8*34.6*32.9	280	89	19.8	50	3.8	15.5
K2323-1220IV	0-8in*0.001	50	20.7/22	61.8*34.6*32.9	280	89	19.8	50	3.8	15.5

● **OPENING SHOCK DOUBLE PROOF DIAL CALIPER**  
开式双向防震带表卡尺

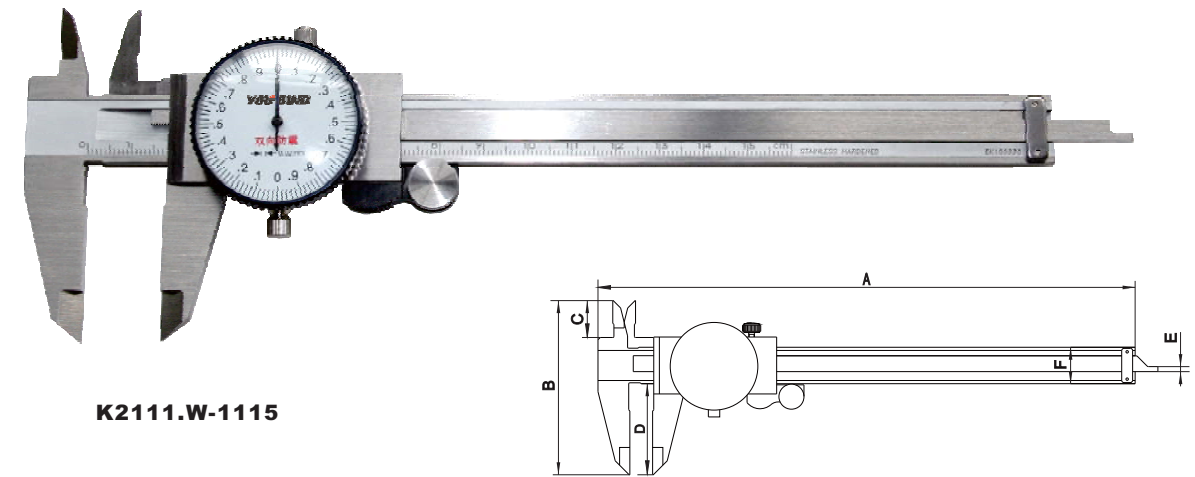

**K2111.W-1115**

● **Features 特性**

- DIN862  
DIN862标准
- Double shock proof  
双向防震
- Zero set  
0位微调
- Dust free  
防尘设计
- Stainless Hardened  
不锈钢淬硬
- Outside  
外测量面
- Inside  
内测量面
- Depth  
深度测量面
- Step  
台阶测量面
- Dial color optional  
表盘颜色可选

● **Optional features 可选功能**

- Without  
Roller wheel  
无滚轮

	Specification 规格	QTY/CTN 装箱数量	N. W. /G. W. 净重/毛重(kg)	Meas(cm) 外箱尺寸	A	B	C	D	E	F
K2111-1115	0-150mm*0.01	50	15.2/17.8	51.3*26.8*32	236	76.5	16.5	40	1.7	16
K2112-1115	0-150mm*0.02	50	15.2/17.8	51.3*26.8*32	236	76.5	16.5	40	1.7	16
K2113-1115	0-6in*0.001	50	15.2/17.8	51.3*26.8*32	236	76.5	16.5	40	1.7	16
K2111-1120	0-200mm*0.01	50	18.6/22.9	61.8*34.6*32.9	290	90	19.7	50	1.7	16
K2112-1120	0-200mm*0.02	50	18.6/22.9	61.8*34.6*32.9	290	90	19.7	50	1.7	16
K2113-1120	0-8in*0.001	50	18.6/22.9	61.8*34.6*32.9	290	90	19.7	50	1.7	16
K2111-1130	0-300mm*0.01	20	15.8/17.3	45.5*29*38.3	405	112.5	22	65	1.7	20
K2112-1130	0-300mm*0.02	20	15.8/17.3	45.5*29*38.3	405	112.5	22	65	1.7	20
K2113-1130	0-12in*0.001	20	15.8/17.3	45.5*29*38.3	405	112.5	22	65	1.7	20

● **VERNIER CALIPER MONO BLOCK**  
整体游标卡尺

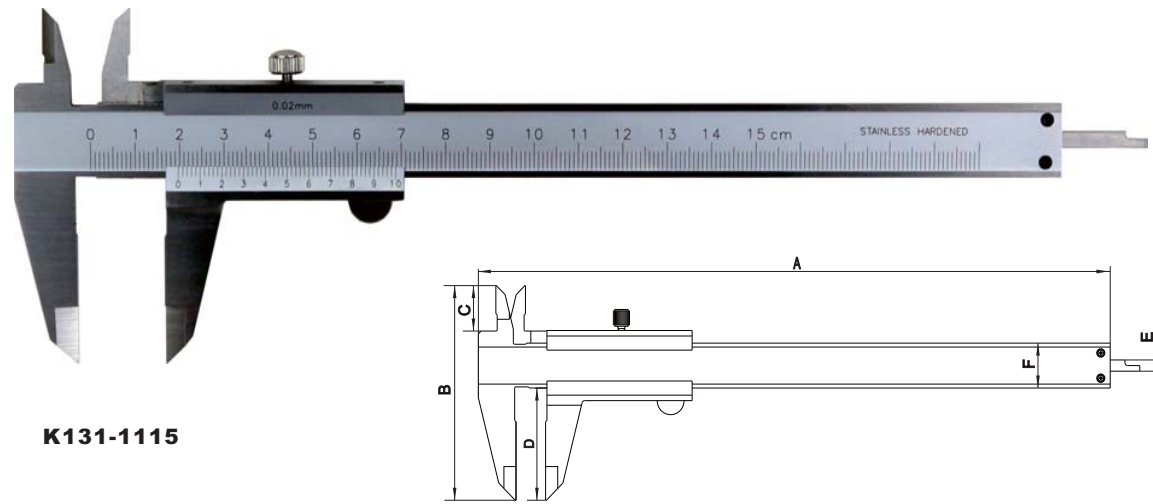

**K131-1115**

● **Features 特性**



● **Optional features 可选功能**



● **VERNIER CALIPER MONO BLOCK**  
整体游标卡尺

	Specification 规格	QTY/CTN 装箱数量	N. W. / G. W. 净重/毛重 (kg)	Meas(cm) 外箱尺寸	A	B	C	D	E	F
K131-1110	0-100mm*0.02	50	12.8/15	51*27*26.7	178	76.5	16.5	40	4	16
K132-1110	0-100mm*0.05	50	12.8/15	51*27*26.7	178	76.5	16.5	40	4	16
K133-1110	0-100mm*0.02/0-4in*0.001	50	12.8/15	51*27*26.7	178	76.5	16.5	40	4	16
K134-1110	0-4in*0.001/0-100mm*0.02	50	12.8/15	51*27*26.7	178	76.5	16.5	40	4	16
K135-1110	0-100mm*0.05/0-4in*1/128	50	12.8/15	51*27*26.7	178	76.5	16.5	40	4	16
K136-1110	0-4in*1/128/0-100mm*0.05	50	12.8/15	51*27*26.7	185	76.5	16.5	40	4	16
K131-1115	0-150mm*0.02	50	13.5/15.7	51*27*26.7	236	76.5	16.5	40	4	16
K132-1115	0-150mm*0.05	50	13.5/15.7	51*27*26.7	236	76.5	16.5	40	4	16
K133-1115	0-150mm*0.02/0-6in*0.001	50	13.5/15.7	51*27*26.7	236	76.5	16.5	40	4	16
K134-1115	0-6in*0.001/0-150mm*0.02	50	13.5/15.7	51*27*26.7	236	76.5	16.5	40	4	16
K135-1115	0-150mm*0.05/0-6in*1/128	50	13.5/15.7	51*27*26.7	236	76.5	16.5	40	4	16
K136-1115	0-6in*1/128/0-150mm*0.05	50	13.5/15.7	51*27*26.7	236	76.5	16.5	40	4	16
K131-1120	0-200mm*0.02	50	17.2/20	59.5*33.7*27.5	290	90	19.7	50	4	16
K132-1120	0-200mm*0.05	50	17.2/20	59.5*33.7*27.5	290	90	19.7	50	4	16
K133-1120	0-200mm*0.02/0-8in*0.001	50	17.2/20	59.5*33.7*27.5	290	90	19.7	50	4	16
K134-1120	0-8in*0.001/0-200mm*0.02	50	17.2/20	59.5*33.7*27.5	290	90	19.7	50	4	16
K135-1120	0-200mm*0.05/0-8in*1/128	50	17.2/20	59.5*33.7*27.5	290	90	19.7	50	4	16
K136-1120	0-8in*1/128/0-200mm*0.05	50	17.2/20	59.5*33.7*27.5	290	90	19.7	50	4	16
K131-1130	0-300mm*0.02	20	15.8/17.3	45.5*29*38.3	414	112.5	22.1	65	4	20
K132-1130	0-300mm*0.05	20	15.8/17.3	45.5*29*38.3	414	112.5	22.1	65	4	20
K133-1130	0-300mm*0.02/0-12in*0.001	20	15.8/17.3	45.5*29*38.3	414	112.5	22.1	65	4	20
K134-1130	0-12in*0.001/0-300mm*0.02	20	15.8/17.3	45.5*29*38.3	414	112.5	22.1	65	4	20
K135-1130	0-300mm*0.05/0-12in*1/128	20	15.8/17.3	45.5*29*38.3	414	112.5	22.1	65	4	20
K136-1130	0-12in*1/128/0-300mm*0.05	20	15.8/17.3	45.5*29*38.3	414	112.5	22.1	65	4	20

● **VERNIER CALIPER MONO BLOCK WITH AUTO LOCK**  
整体小自锁游标卡尺

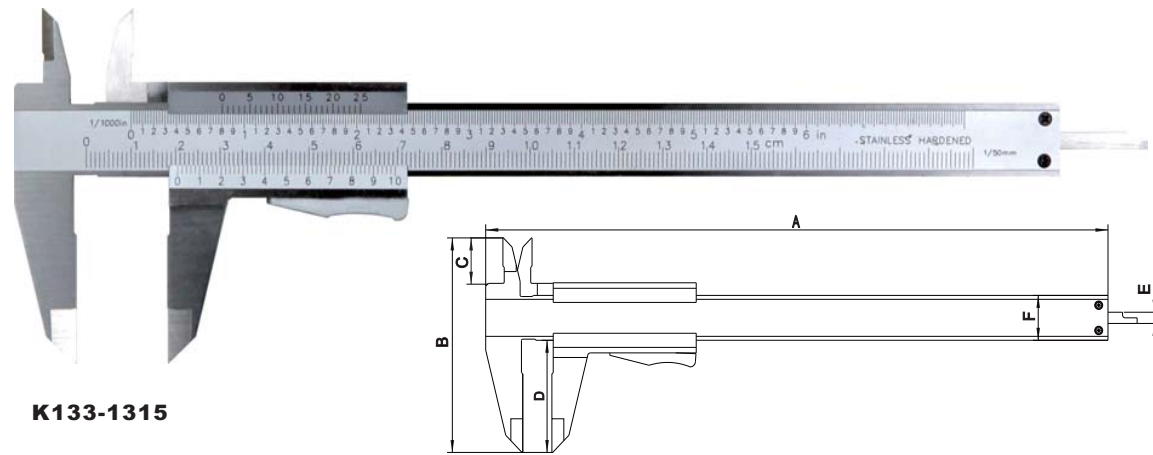

**K133-1315**

● Features 特性



● Optional features 可选功能



	Specification 规格	QTY/CTN 装箱数量	N. W. /G. W. 净重/毛重(kg)	Meas(cm) 外箱尺寸	A	B	C	D	E	F
K131-1310	0-100mm*0.02	50	12.8/15	51*27*26.7	178	76.5	16.5	40	4	16
K132-1310	0-100mm*0.05	50	12.8/15	51*27*26.7	178	76.5	16.5	40	4	16
K133-1310	0-100mm*0.02/0-4in*0.001	50	12.8/15	51*27*26.7	178	76.5	16.5	40	4	16
K134-1310	0-4in*0.001/0-100mm*0.02	50	12.8/15	51*27*26.7	178	76.5	16.5	40	4	16
K135-1310	0-100mm*0.05/0-4in*1/128	50	12.8/15	51*27*26.7	178	76.5	16.5	40	4	16
K136-1310	0-4in*1/128/0-100mm*0.05	50	12.8/15	51*27*26.7	185	76.5	16.5	40	4	16
K131-1315	0-150mm*0.02	50	13.5/15.7	51*27*26.7	236	76.5	16.5	40	4	16
K132-1315	0-150mm*0.05	50	13.5/15.7	51*27*26.7	236	76.5	16.5	40	4	16
K133-1315	0-150mm*0.02/0-6in*0.001	50	13.5/15.7	51*27*26.7	236	76.5	16.5	40	4	16
K134-1315	0-6in*0.001/0-150mm*0.02	50	13.5/15.7	51*27*26.7	236	76.5	16.5	40	4	16
K135-1315	0-150mm*0.05/0-6in*1/128	50	13.5/15.7	51*27*26.7	236	76.5	16.5	40	4	16
K136-1315	0-6in*1/128/0-150mm*0.05	50	13.5/15.7	51*27*26.7	236	76.5	16.5	40	4	16
K131-1320	0-200mm*0.02	50	17.2/20	59.5*33.7*27.5	290	90	19.7	50	4	16
K132-1320	0-200mm*0.05	50	17.2/20	59.5*33.7*27.5	290	90	19.7	50	4	16
K133-1320	0-200mm*0.02/0-8in*0.001	50	17.2/20	59.5*33.7*27.5	290	90	19.7	50	4	16
K134-1320	0-8in*0.001/0-200mm*0.02	50	17.2/20	59.5*33.7*27.5	290	90	19.7	50	4	16
K135-1320	0-200mm*0.05/0-8in*1/128	50	17.2/20	59.5*33.7*27.5	290	90	19.7	50	4	16
K136-1320	0-8in*1/128/0-200mm*0.05	50	17.2/20	59.5*33.7*27.5	290	90	19.7	50	4	16

● **VERNIER CALIPER MONO BLOCK WITH AUTO LOCK**  
整体内自锁游标卡尺

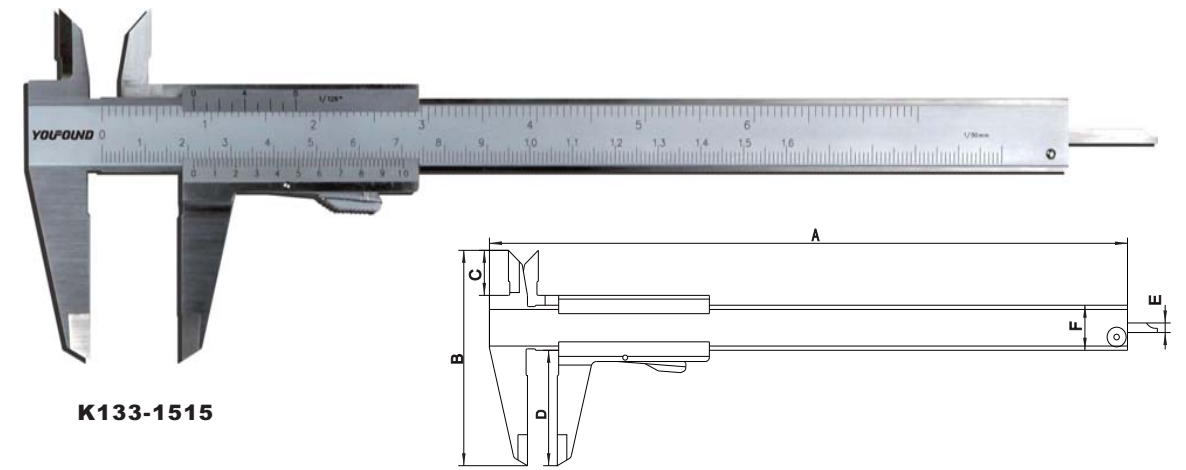

**K133-1515**

● Features 特性



● Optional features 可选功能



	Specification 规格	QTY/CTN 装箱数量	N. W. /G. W. 净重/毛重(kg)	Meas(cm) 外箱尺寸	A	B	C	D	E	F
K131-1510	0-100mm*0.02	50	12.8/15	51*27*26.7	178	76.5	16	41	3.4	16
K132-1510	0-100mm*0.05	50	12.8/15	51*27*26.7	178	76.5	16	41	3.4	16
K133-1510	0-100mm*0.02/0-4in*0.001	50	12.8/15	51*27*26.7	178	76.5	16	41	3.4	16
K134-1510	0-4in*0.001/0-100mm*0.02	50	12.8/15	51*27*26.7	178	76.5	16	41	3.4	16
K135-1510	0-100mm*0.05/0-4in*1/128	50	12.8/15	51*27*26.7	178	76.5	16	41	3.4	16
K136-1510	0-4in*1/128/0-100mm*0.05	50	12.8/15	51*27*26.7	178	76.5	16	41	3.4	16
K131-1515	0-150mm*0.02	50	13.5/15.7	51*27*26.7	235	76.5	16	41	3.4	16
K132-1515	0-150mm*0.05	50	13.5/15.7	51*27*26.7	235	76.5	16	41	3.4	16
K133-1515	0-150mm*0.02/0-6in*0.001	50	13.5/15.7	51*27*26.7	235	76.5	16	41	3.4	16
K134-1515	0-6in*0.001/0-150mm*0.02	50	13.5/15.7	51*27*26.7	235	76.5	16	41	3.4	16
K135-1515	0-150mm*0.05/0-6in*1/128	50	13.5/15.7	51*27*26.7	235	76.5	16	41	3.4	16
K136-1515	0-6in*1/128/0-150mm*0.05	50	13.5/15.7	51*27*26.7	235	76.5	16	41	3.4	16
K131-1520	0-200mm*0.02	50	17.2/20	59.5*33.7*27.5	285	76.5	16	41	3.4	16
K132-1520	0-200mm*0.05	50	17.2/20	59.5*33.7*27.5	285	76.5	16	41	3.4	16
K133-1520	0-200mm*0.02/0-8in*0.001	50	17.2/20	59.5*33.7*27.5	285	76.5	16	41	3.4	16
K134-1520	0-8in*0.001/0-200mm*0.02	50	17.2/20	59.5*33.7*27.5	285	76.5	16	41	3.4	16
K135-1520	0-200mm*0.05/0-8in*1/128	50	17.2/20	59.5*33.7*27.5	285	76.5	16	41	3.4	16
K136-1520	0-8in*1/128/0-200mm*0.05	50	17.2/20	59.5*33.7*27.5	285	76.5	16	41	3.4	16

● **VERNIER CALIPER MONO BLOCK WITH LARGE AUTO LOCK**  
整体大自锁游标卡尺

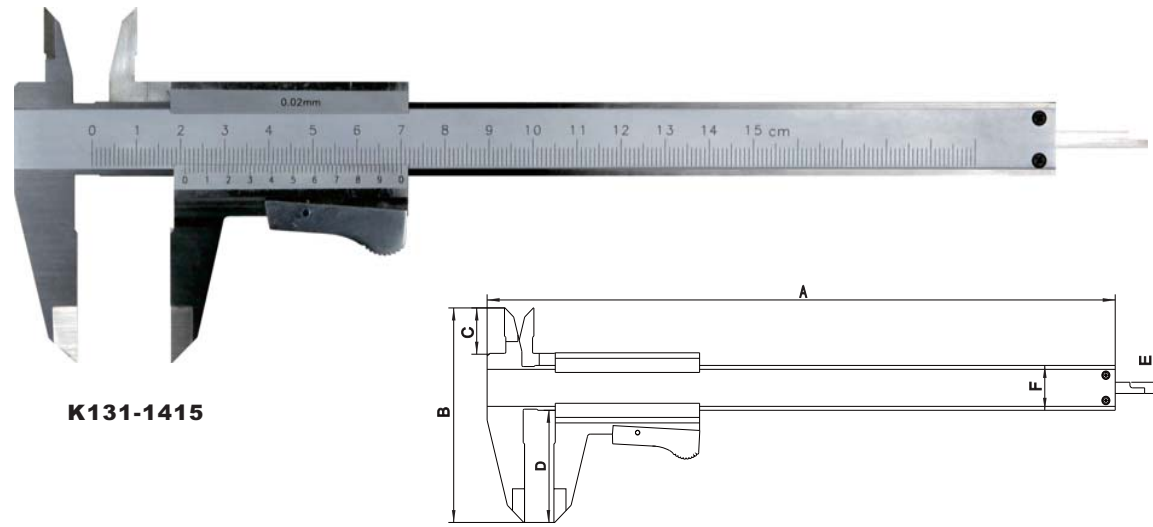

**K131-1415**

● **Features 特性**



● **Optional features 可选功能**



● **VERNIER CALIPER MONO BLOCK WITH LARGE AUTO LOCK**  
整体大自锁游标卡尺

	Specification 规格	QTY/CTN 装箱数量	N. W. / G. W. 净重/毛重 (kg)	Meas(cm) 外箱尺寸	A	B	C	D	E	F
K131-1410	0-100mm*0.02	50	12.8/15	51*27*26.7	178	76.5	16.5	40	4	16
K132-1410	0-100mm*0.05	50	12.8/15	51*27*26.7	178	76.5	16.5	40	4	16
K133-1410	0-100mm*0.02/0-4in*0.001	50	12.8/15	51*27*26.7	178	76.5	16.5	40	4	16
K134-1410	0-4in*0.001/0-100mm*0.02	50	12.8/15	51*27*26.7	178	76.5	16.5	40	4	16
K135-1410	0-100mm*0.05/0-4in*1/128	50	12.8/15	51*27*26.7	178	76.5	16.5	40	4	16
K136-1410	0-4in*1/128/0-100mm*0.05	50	12.8/15	51*27*26.7	178	76.5	16.5	40	4	16
K131-1415	0-150mm*0.02	50	13.5/15.7	51*27*26.7	236	76.5	16.5	40	4	16
K132-1415	0-150mm*0.05	50	13.5/15.7	51*27*26.7	236	76.5	16.5	40	4	16
K133-1415	0-150mm*0.02/0-6in*0.001	50	13.5/15.7	51*27*26.7	236	76.5	16.5	40	4	16
K134-1415	0-6in*0.001/0-150mm*0.02	50	13.5/15.7	51*27*26.7	236	76.5	16.5	40	4	16
K135-1415	0-150mm*0.05/0-6in*1/128	50	13.5/15.7	51*27*26.7	236	76.5	16.5	40	4	16
K136-1415	0-6in*1/128/0-150mm*0.05	50	13.5/15.7	51*27*26.7	236	76.5	16.5	40	4	16
K131-1420	0-200mm*0.02	50	17.2/20	59.5*33.7*27.5	290	90	19.7	50	4	16
K132-1420	0-200mm*0.05	50	17.2/20	59.5*33.7*27.5	290	90	19.7	50	4	16
K133-1420	0-200mm*0.02/0-8in*0.001	50	17.2/20	59.5*33.7*27.5	290	90	19.7	50	4	16
K134-1420	0-8in*0.001/0-200mm*0.02	50	17.2/20	59.5*33.7*27.5	290	90	19.7	50	4	16
K135-1420	0-200mm*0.05/0-8in*1/128	50	17.2/20	59.5*33.7*27.5	290	90	19.7	50	4	16
K136-1420	0-8in*1/128/0-200mm*0.05	50	17.2/20	59.5*33.7*27.5	290	90	19.7	50	4	16
K131-1430	0-300mm*0.02	20	15.8/17.3	45.5*29*38.3	414	112.5	22.1	65	4	20
K132-1430	0-300mm*0.05	20	15.8/17.3	45.5*29*38.3	414	112.5	22.1	65	4	20
K133-1430	0-300mm*0.02/0-12in*0.001	20	15.8/17.3	45.5*29*38.3	414	112.5	22.1	65	4	20
K134-1430	0-12in*0.001/0-300mm*0.02	20	15.8/17.3	45.5*29*38.3	414	112.5	22.1	65	4	20
K135-1430	0-300mm*0.05/0-12in*1/128	20	15.8/17.3	45.5*29*38.3	414	112.5	22.1	65	4	20
K136-1430	0-12in*1/128/0-300mm*0.05	20	15.8/17.3	45.5*29*38.3	414	112.5	22.1	65	4	20

● **VERNIER CALIPER WITH METRIC ( OR/ WITH INCH) SCALE**  
分体游标卡尺

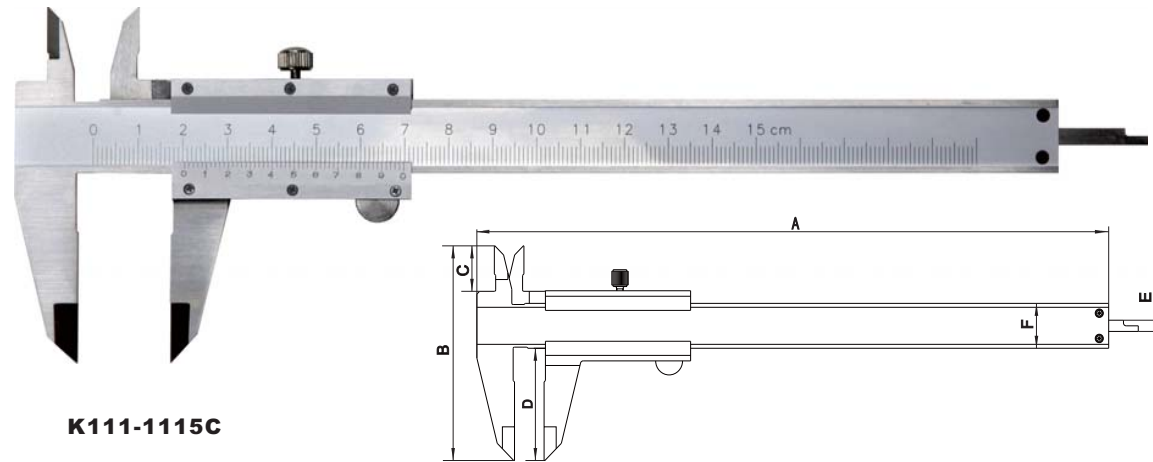

**K111-1115C**

● **Features 特性**



● **Optional features 可选功能**



	Specification 规格	QTY/CTN 装箱数量	N. W. /G. W. 净重/毛重(kg)	Meas(cm) 外箱尺寸	A	B	C	D	E	F
K111-1115C	0-150mm*0.02	50	13.5/15.7	51*27*26.7	236	76.5	16.5	40	4	16
K112-1115C	0-150mm*0.05	50	13.5/15.7	51*27*26.7	236	76.5	16.5	40	4	16
K113-1115C	0-150mm*0.02/0-6in*0.001	50	13.5/15.7	51*27*26.7	236	76.5	16.5	40	4	16
K114-1115C	0-6in*0.001/0-150mm*0.02	50	13.5/15.7	51*27*26.7	236	76.5	16.5	40	4	16
K115-1115C	0-150mm*0.05/0-6in*1/128	50	13.5/15.7	51*27*26.7	236	76.5	16.5	40	4	16
K116-1115C	0-6in*1/128/0-150mm*0.05	50	13.5/15.7	51*27*26.7	236	76.5	16.5	40	4	16
K111-1120C	0-200mm*0.02	50	17.2/20	59.5*33.7*27.5	290	90	19.7	50	4	16
K112-1120C	0-200mm*0.05	50	17.2/20	59.5*33.7*27.5	290	90	19.7	50	4	16
K113-1120C	0-200mm*0.02/0-8in*0.001	50	17.2/20	59.5*33.7*27.5	290	90	19.7	50	4	16
K114-1120C	0-8in*0.001/0-200mm*0.02	50	17.2/20	59.5*33.7*27.5	290	90	19.7	50	4	16
K115-1120C	0-200mm*0.05/0-8in*1/128	50	17.2/20	59.5*33.7*27.5	290	90	19.7	50	4	16
K116-1120C	0-8in*1/128/0-200mm*0.05	50	17.2/20	59.5*33.7*27.5	290	90	19.7	50	4	16
K111-1130C	0-300mm*0.02	20	15.8/17.3	45.5*29*38.3	414	112.5	22.1	65	4	20
K112-1130C	0-300mm*0.05	20	15.8/17.3	45.5*29*38.3	414	112.5	22.1	65	4	20
K113-1130C	0-300mm*0.02/0-12in*0.001	20	15.8/17.3	45.5*29*38.3	414	112.5	22.1	65	4	20
K114-1130C	0-12in*0.001/0-300mm*0.02	20	15.8/17.3	45.5*29*38.3	414	112.5	22.1	65	4	20
K115-1130C	0-300mm*0.05/0-12in*1/128	20	15.8/17.3	45.5*29*38.3	414	112.5	22.1	65	4	20
K116-1130C	0-12in*1/128/0-300mm*0.05	20	15.8/17.3	45.5*29*38.3	414	112.5	22.1	65	4	20

● **VERNIER CALIPER WITH AUTO LOCK**  
分体大自锁游标卡尺

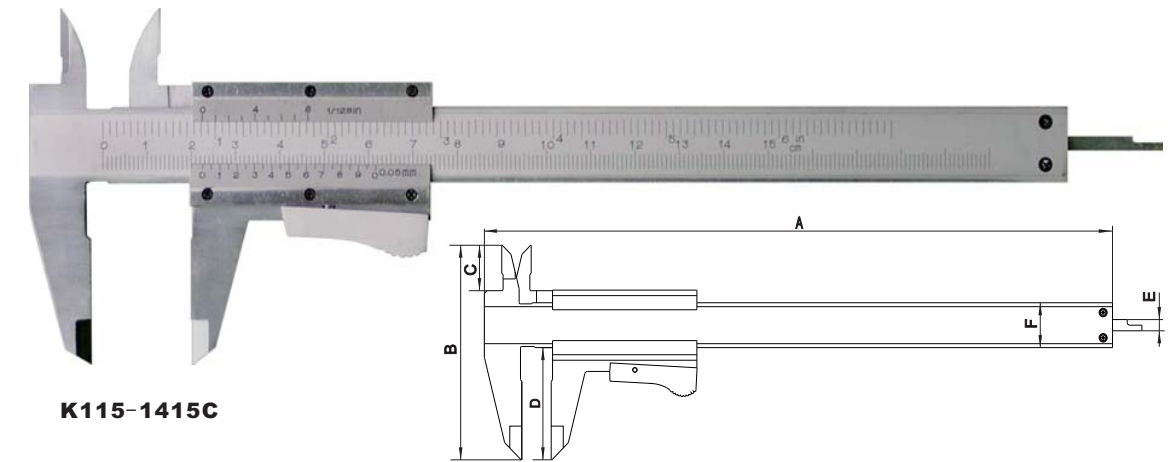

**K115-1415C**

● **Features 特性**



● **Optional features 可选功能**



	Specification 规格	QTY/CTN 装箱数量	N. W. /G. W. 净重/毛重(kg)	Meas(cm) 外箱尺寸	A	B	C	D	E	F
K111-1415C	0-150mm*0.02	50	13.5/15.7	51*27*26.7	236	76.5	16.5	40	4	16
K112-1415C	0-150mm*0.05	50	13.5/15.7	51*27*26.7	236	76.5	16.5	40	4	16
K113-1415C	0-150mm*0.02/0-6in*0.001	50	13.5/15.7	51*27*26.7	236	76.5	16.5	40	4	16
K114-1415C	0-6in*0.001/0-150mm*0.02	50	13.5/15.7	51*27*26.7	236	76.5	16.5	40	4	16
K115-1415C	0-150mm*0.05/0-6in*1/128	50	13.5/15.7	51*27*26.7	236	76.5	16.5	40	4	16
K116-1415C	0-6in*1/128/0-150mm*0.05	50	13.5/15.7	51*27*26.7	236	76.5	16.5	40	4	16
K111-1420C	0-200mm*0.02	50	17.2/20	59.5*33.7*27.5	290	90	19.7	50	4	16
K112-1420C	0-200mm*0.05	50	17.2/20	59.5*33.7*27.5	290	90	19.7	50	4	16
K113-1420C	0-200mm*0.02/0-8in*0.001	50	17.2/20	59.5*33.7*27.5	290	90	19.7	50	4	16
K114-1420C	0-8in*0.001/0-200mm*0.02	50	17.2/20	59.5*33.7*27.5	290	90	19.7	50	4	16
K115-1420C	0-200mm*0.05/0-8in*1/128	50	17.2/20	59.5*33.7*27.5	290	90	19.7	50	4	16
K116-1420C	0-8in*1/128/0-200mm*0.05	50	17.2/20	59.5*33.7*27.5	290	90	19.7	50	4	16
K111-1430C	0-300mm*0.02	20	15.8/17.3	45.5*29*38.3	414	112.5	22.1	65	4	20
K112-1430C	0-300mm*0.05	20	15.8/17.3	45.5*29*38.3	414	112.5	22.1	65	4	20
K113-1430C	0-300mm*0.02/0-12in*0.001	20	15.8/17.3	45.5*29*38.3	414	112.5	22.1	65	4	20
K114-1430C	0-12in*0.001/0-300mm*0.02	20	15.8/17.3	45.5*29*38.3	414	112.5	22.1	65	4	20
K115-1430C	0-300mm*0.05/0-12in*1/128	20	15.8/17.3	45.5*29*38.3	414	112.5	22.1	65	4	20
K116-1430C	0-12in*1/128/0-300mm*0.05	20	15.8/17.3	45.5*29*38.3	414	112.5	22.1	65	4	20

● **VERNIER CALIPER WITH FINE ADJUSTMENT**  
开式微动游标卡尺

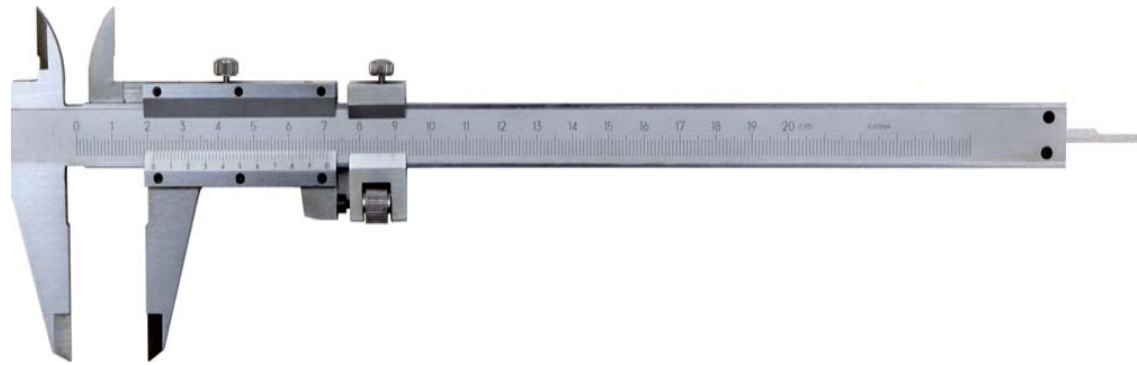

**K111.WK-1115**

● **Features 特性**



● **Optional features 可选功能**



	Specification 规格	QTY/CTN 装箱数量	N. W. / G. W. 净重/毛重(kg)	Meas(cm) 外箱尺寸					
K111.WK-1115C	0-150mm*0.02								
K112.WK-1115C	0-150mm*0.05								
K113.WK-1115C	0-150mm*0.02/0-6in*0.001								
K114.WK-1115C	0-6in*0.001/0-150mm*0.02								
K115.WK-1115C	0-150mm*0.05/0-6in*1/128								
K116.WK-1115C	0-6in*1/128/0-150mm*0.05								
K111.WK-1120C	0-200mm*0.02								
K112.WK-1120C	0-200mm*0.05								
K113.WK-1120C	0-200mm*0.02/0-8in*0.001								
K114.WK-1120C	0-8in*0.001/0-200mm*0.02								
K115.WK-1120C	0-200mm*0.05/0-8in*1/128								
K116.WK-1120C	0-8in*1/128/0-200mm*0.05								
K111.WK-1130C	0-300mm*0.02								
K112.WK-1130C	0-300mm*0.05								
K113.WK-1130C	0-300mm*0.02/0-12in*0.001								
K114.WK-1130C	0-12in*0.001/0-300mm*0.02								
K115.WK-1130C	0-300mm*0.05/0-12in*1/128								
K116.WK-1130C	0-12in*1/128/0-300mm*0.05								

● **3-KEY DIGITAL DEPTH GAUGE WITH STANDARD SCREEN**  
3按键普通屏电子数显深度尺

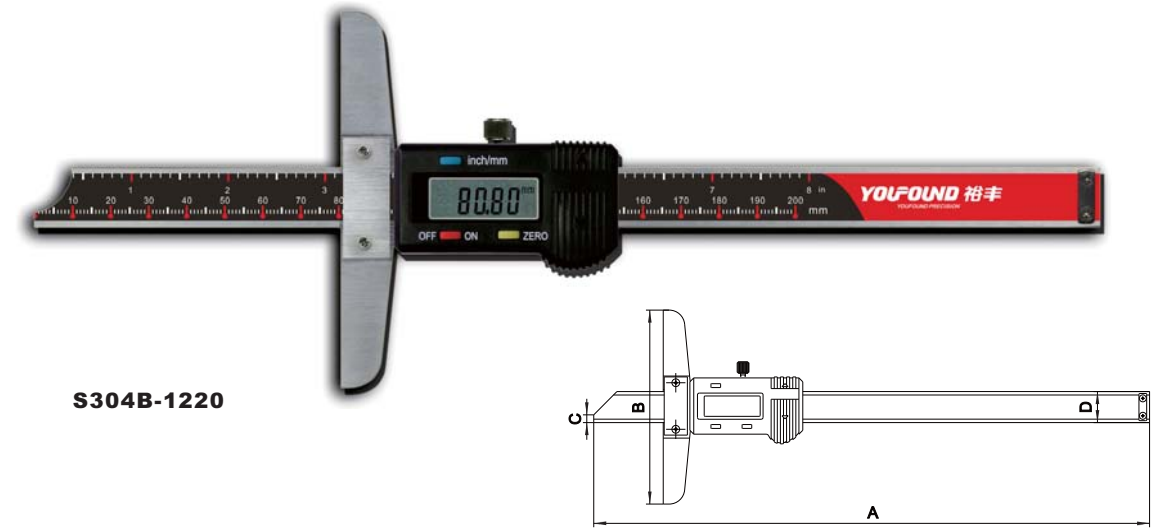

**S304B-1220**

● **Features 特性**



● **Optional features 可选功能**



	Specification 规格	QTY/CTN 装箱数量	N. W. / G. W. 净重/毛重(kg)	Meas(cm) 外箱尺寸	A	B	C	D
S304B-1210	0-100mm*0.01/0-4in*0.0005	50	19.8/23	61.8*34.6*32.9	188	100	4	16
S304B-1215	0-150mm*0.01/0-6in*0.0005	50	20.5/23.7	61.8*34.6*32.9	238	100	4	16
S304B-1220	0-200mm*0.01/0-8in*0.0005	50	21.7/24.9	61.8*34.6*32.9	288	100	4	16
S304B-1230	0-300mm*0.01/0-12in*0.0005	20	12.9/15.9	46.3*30.4*36.2	393	100	4	16

● **3-KEY DIGITAL DEPTH GAUGE WITH LARGE SCREEN**  
3按键大屏电子数显深度尺

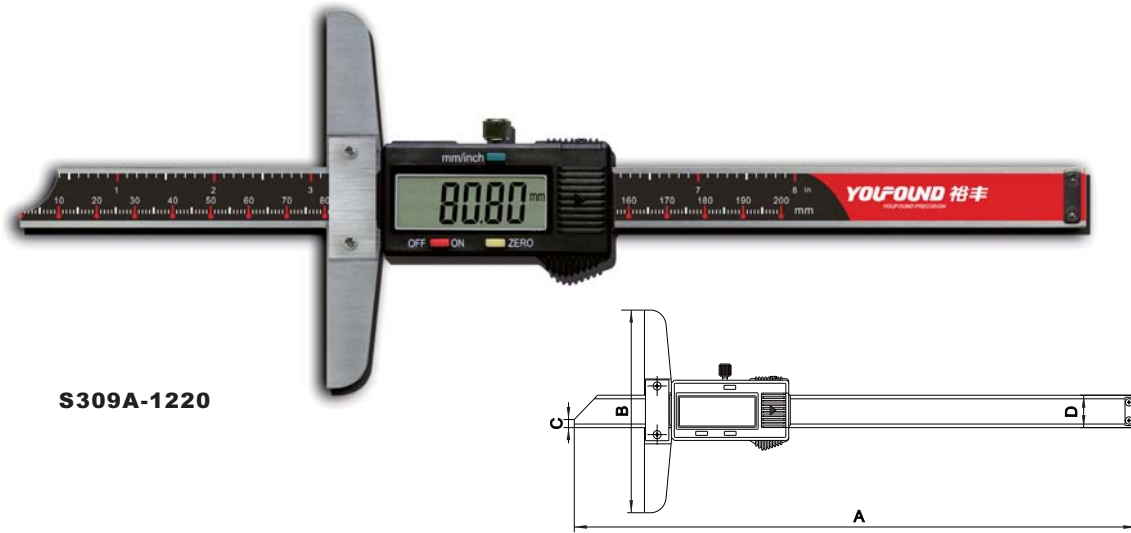

S309A-1220

● Features 特性

- DIN862  
DIN862标准
- Number size 11mm  
11mm字高
- Arbitrary set zero  
任意位置置零
- MM-IN  
公英制转换
- Max moving speed 1.5m/s  
最大移动速度 1.5米/秒
- Stainless Hardened  
不锈钢淬硬

● Optional features 可选功能

- Normal  
常规量面
- With Hook  
单勾头
- Double Hook  
双勾头
- Pin  
针头
- Normal 2  
圆弧量面
- Length Measuring Face  
加长测量面
- Titanize  
表面镀钛
- USB  
USB模式接口
- Max moving speed 3m/s  
最大移动速度 3米/秒
- Auto off  
自动断电可选

● Optional calipers 可选款式

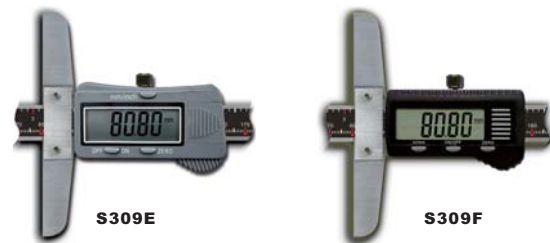

S309E

S309F

	Specification 规格	QTY/CTN 装箱数量	N. W. /G. W. 净重/毛重(kg)	Meas(cm) 外箱尺寸	A	B	C	D
S309A-1210	0-100mm*0.01/0-4in*0.0005	50	19.8/23	61.8*34.6*32.9	188	100	4	16
S309A-1215	0-150mm*0.01/0-6in*0.0005	50	20.5/23.7	61.8*34.6*32.9	238	100	4	16
S309A-1220	0-200mm*0.01/0-8in*0.0005	50	21.7/24.9	61.8*34.6*32.9	288	100	4	16
S309A-1230	0-300mm*0.01/0-12in*0.0005	20	12.9/15.9	46.3*30.4*36.2	393	100	4	16

● **DIGITAL DEPTH GAUGE WITH METAL CASING**  
金属罩壳电子数显深度尺

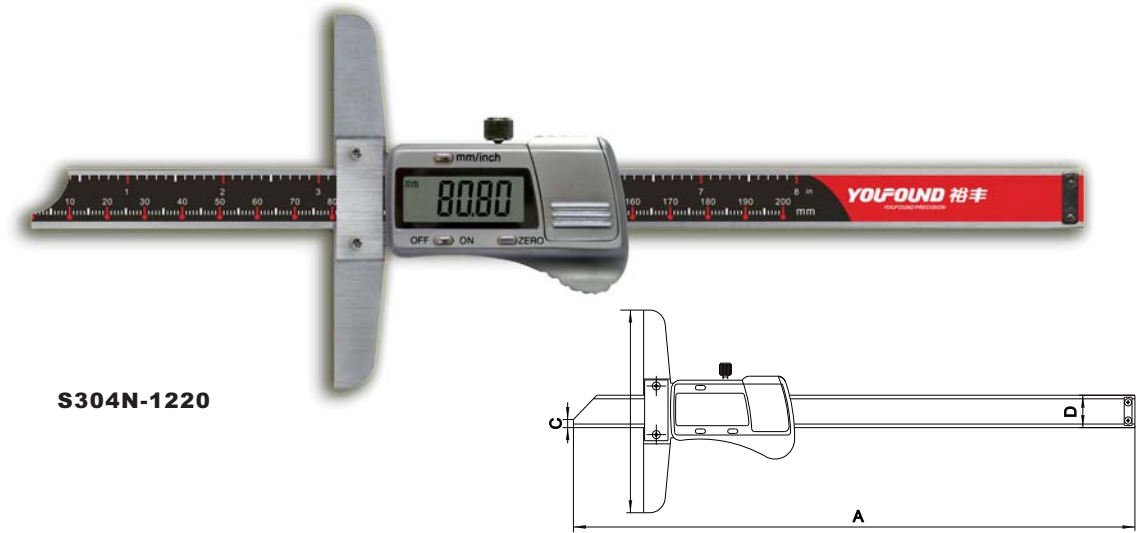

S304N-1220

● Features 特性

- DIN862  
DIN862标准
- Metal casing  
金属罩壳
- Number size 11mm  
11mm字高
- Arbitrary set zero  
任意位置置零
- MM-IN  
公英制转换
- Max moving speed 1.5m/s  
最大移动速度 1.5米/秒
- Stainless Hardened  
不锈钢淬硬

● Optional features 可选功能

- Normal  
常规量面
- With Hook  
单勾头
- Double Hook  
双勾头
- Pin  
针头
- Normal 2  
圆弧量面
- Length Measuring Face  
加长测量面
- Titanize  
表面镀钛
- Max moving speed 3m/s  
最大移动速度 3米/秒
- Auto off  
自动断电可选

● Optional calipers 可选款式



S309G

S309H

S309N

S309Q

S309O

	Specification 规格	QTY/CTN 装箱数量	N. W. /G. W. 净重/毛重(kg)	Meas(cm) 外箱尺寸	A	B	C	D
S304N-1210	0-100mm*0.01/0-4in*0.0005	50	19.8/23	61.8*34.6*32.9	188	100	4	16
S304N-1215	0-150mm*0.01/0-6in*0.0005	50	20.5/23.7	61.8*34.6*32.9	238	100	4	16
S304N-1220	0-200mm*0.01/0-8in*0.0005	50	21.7/24.9	61.8*34.6*32.9	288	100	4	16
S304N-1230	0-300mm*0.01/0-12in*0.0005	20	12.9/15.9	46.3*30.4*36.2	393	100	4	16

● **4-KEY DIGITAL DEPTH GAUGE**  
4按键电子数显深度尺

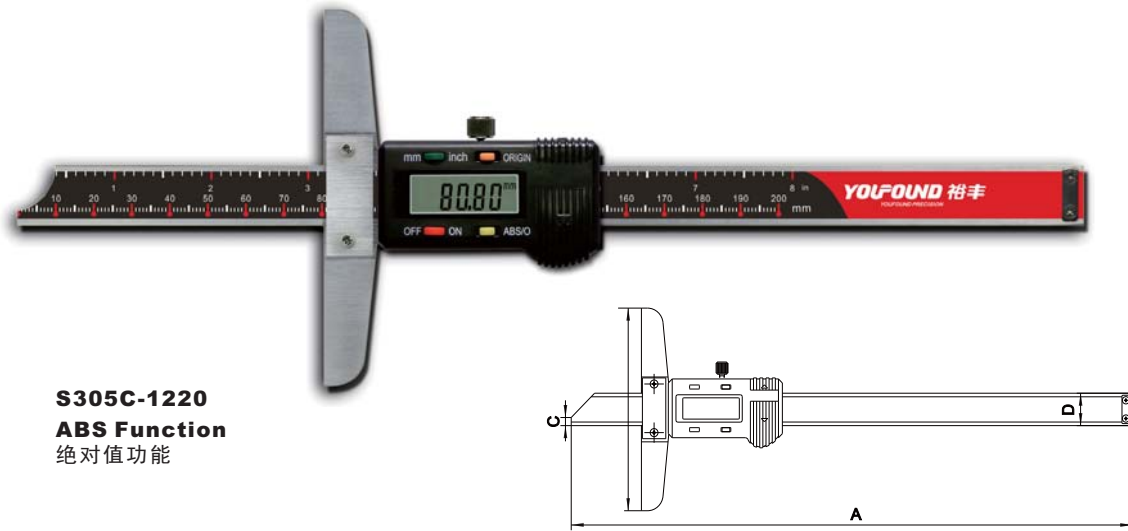

**S305C-1220**  
**ABS Function**  
绝对值功能

● Features 特性

- Din 862**  
DIN862  
DIN862标准
- multi function**  
Multi function  
多种测量功能
- 0**  
Arbitrary set zero  
任意位置置零
- mm In**  
MM-IN  
公英制转换
- 1.5**  
Max moving speed 1.5m/s  
最大移动速度 1.5米/秒
- Stainless Hardened**  
不锈钢淬硬

● Optional features 可选功能

- Normal**  
常规量面
- With Hook**  
单勾头
- Double Hook**  
双勾头
- Pin**  
针头
- Normal 2**  
圆弧量面
- Length Measuring Face**  
加长测量面
- Ti**  
Titanize  
表面镀钛
- USB**  
USB  
模式接口
- 3**  
Max moving speed 3m/s  
最大移动速度 3米/秒
- Auto off**  
自动断电  
可选

● Optional calipers 可选款式



	Specification 规格	QTY/CTN 装箱数量	N. W. /G. W. 净重/毛重 (kg)	Meas(cm) 外箱尺寸	A	B	C	D
S305C-1210	0-100mm*0.01/0-4in*0.0005	50	19.8/23	61.8*34.6*32.9	188	100	4	16
S305C-1215	0-150mm*0.01/0-6in*0.0005	50	20.5/23.7	61.8*34.6*32.9	238	100	4	16
S305C-1220	0-200mm*0.01/0-8in*0.0005	50	21.7/24.9	61.8*34.6*32.9	288	100	4	16
S305C-1230	0-300mm*0.01/0-12in*0.0005	20	12.9/15.9	46.3*30.4*36.2	393	100	4	16

● **IP54 DIGITAL DEPTH GAUGE**  
IP54防护电子数显深度尺

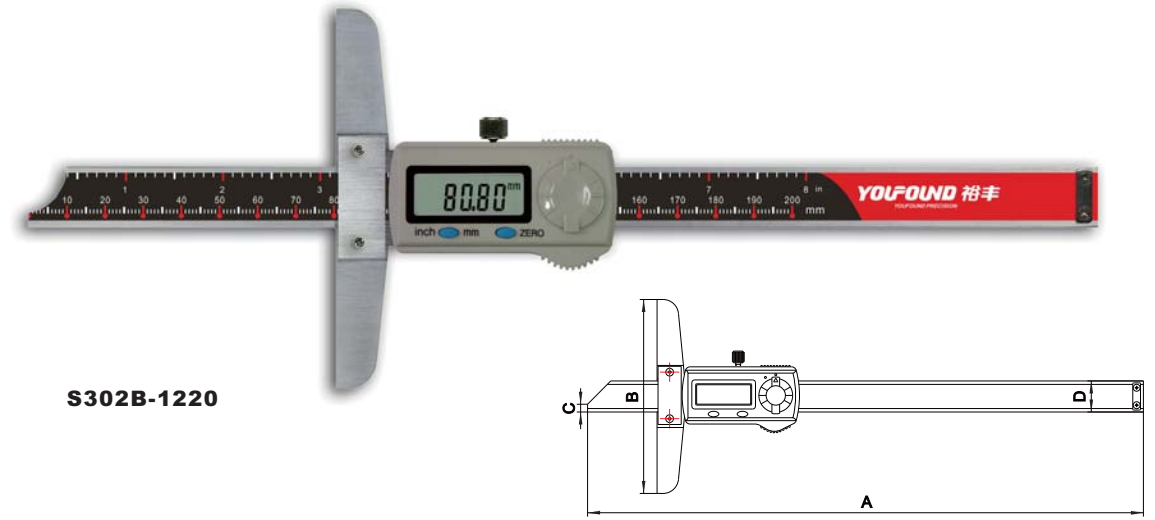

**S302B-1220**

● Features 特性

- Din 862**  
DIN862  
DIN862标准
- Ip54**  
Ip54  
Ip54防护
- 8mm**  
Number size 8mm  
8mm字高
- 0**  
Arbitrary set zero  
任意位置置零
- mm In**  
MM-IN  
公英制转换
- 1.5**  
Max moving speed 1.5m/s  
最大移动速度 1.5米/秒
- Stainless Hardened**  
不锈钢淬硬

● Optional features 可选功能

- Normal**  
常规量面
- With Hook**  
单勾头
- Double Hook**  
双勾头
- Pin**  
针头
- Normal 2**  
圆弧量面
- Length Measuring Face**  
加长测量面
- Ti**  
Titanize  
表面镀钛
- 3**  
Max moving speed 3m/s  
最大移动速度 3米/秒
- Auto off**  
自动断电  
可选

● Optional calipers 可选款式



	Specification 规格	QTY/CTN 装箱数量	N. W. /G. W. 净重/毛重 (kg)	Meas(cm) 外箱尺寸	A	B	C	D
S302B-1210	0-100mm*0.01/0-4in*0.0005	50	19.8/23	61.8*34.6*32.9	188	100	4	16
S302B-1215	0-150mm*0.01/0-6in*0.0005	50	20.5/23.7	61.8*34.6*32.9	238	100	4	16
S302B-1220	0-200mm*0.01/0-8in*0.0005	50	21.7/24.9	61.8*34.6*32.9	288	100	4	16
S302B-1230	0-300mm*0.01/0-12in*0.0005	20	12.9/15.9	46.3*30.4*36.2	393	100	4	16

● **FRACTION DISPLAY DIGITAL DEPTH GAUGE**

英制分数显示电子数显深度尺

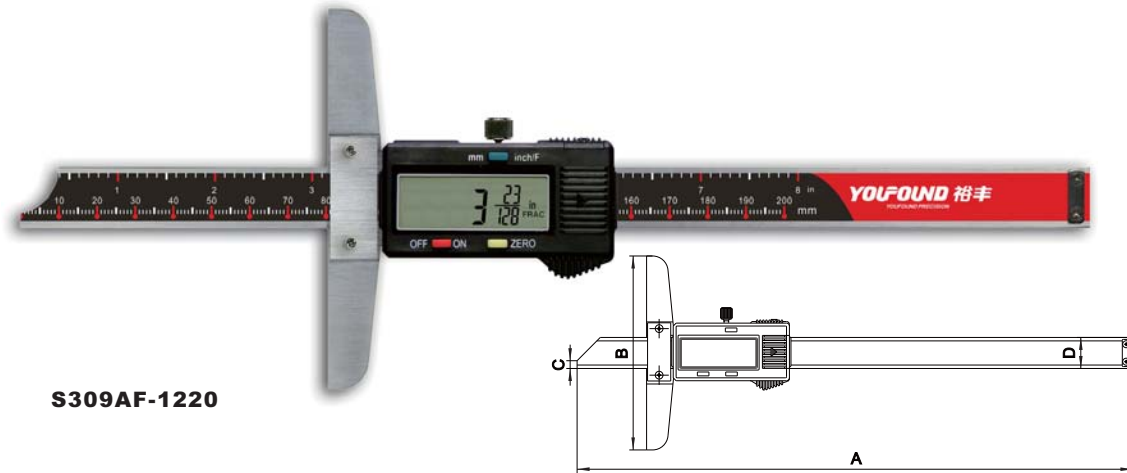

**S309AF-1220**

● **Features 特性**

- DIN862  
DIN862标准
- Number  
size 11mm  
11mm字高
- Fraction  
display  
英制分数显示
- Arbitrary  
set zero  
任意位置  
置零
- MM-IN  
公英制转换
- Max moving  
speed 1.5m/s  
最大移动速度  
1.5米/秒
- Stainless  
Hardened  
不锈钢淬硬

● **Optional features 可选功能**

- Normal  
常规量面
- With Hook  
单勾头
- Double  
Hook  
双勾头
- Pin  
针头
- Normal 2  
圆弧量面
- Length Measuring  
Face  
加长测量面
- Titanize  
表面镀钛
- USB  
模式接口
- Max moving  
speed 3m/s  
最大移动速度  
3米/秒
- Auto off  
自动断电  
可选

● **Optional calipers 可选款式**



● **FRACTION DISPLAY DIGITAL DEPTH GAUGE**

英制分数显示电子数显深度尺

	Specification 规格	QTY/CTN 装箱数量	N. W. /G. W. 净重/毛重 (kg)	Meas(cm) 外箱尺寸	A	B	C	D
S309AF1-1210	0-100mm*0.01/0-4in*0.0005/0-4in*1/64	50	19.8/23	61.8*34.6*32.9	188	100	4	16
S309AF2-1210	0-100mm*0.01/0-4in*0.0005/0-4in*1/128	50	19.8/23	61.8*34.6*32.9	188	100	4	16
S309AF3-1210	0-100mm*0.01/0-4in*0.0005/0-4in*1/256	50	19.8/23	61.8*34.6*32.9	188	100	4	16
S309AF4-1210	0-100mm*0.01/0-4in*0.0005/0-4in*1/32	50	19.8/23	61.8*34.6*32.9	188	100	4	16
S309AF1-1215	0-150mm*0.01/0-6in*0.0005/0-6in*1/64	50	20.5/23.7	61.8*34.6*32.9	238	100	4	16
S309AF2-1215	0-150mm*0.01/0-6in*0.0005/0-6in*1/128	50	20.5/23.7	61.8*34.6*32.9	238	100	4	16
S309AF3-1215	0-150mm*0.01/0-6in*0.0005/0-6in*1/256	50	20.5/23.7	61.8*34.6*32.9	238	100	4	16
S309AF4-1215	0-150mm*0.01/0-6in*0.0005/0-6in*1/32	50	20.5/23.7	61.8*34.6*32.9	238	100	4	16
S309AF1-1220	0-200mm*0.01/0-8in*0.0005/0-8in*1/64	50	21.7/24.9	61.8*34.6*32.9	288	100	4	16
S309AF2-1220	0-200mm*0.01/0-8in*0.0005/0-8in*1/128	50	21.7/24.9	61.8*34.6*32.9	288	100	4	16
S309AF3-1220	0-200mm*0.01/0-8in*0.0005/0-8in*1/256	50	21.7/24.9	61.8*34.6*32.9	288	100	4	16
S309AF4-1220	0-200mm*0.01/0-8in*0.0005/0-8in*1/32	50	21.7/24.9	61.8*34.6*32.9	288	100	4	16
S309AF1-1230	0-300mm*0.01/0-12in*0.0005/0-12in*1/64	20	12.9/15.9	46.3*30.4*37.7	393	100	4	16
S309AF2-1230	0-300mm*0.01/0-12in*0.0005/0-12in*1/128	20	12.9/15.9	46.3*30.4*37.7	393	100	4	16
S309AF3-1230	0-300mm*0.01/0-12in*0.0005/0-12in*1/256	20	12.9/15.9	46.3*30.4*37.7	393	100	4	16
S309AF4-1230	0-300mm*0.01/0-12in*0.0005/0-12in*1/32	20	12.9/15.9	46.3*30.4*37.7	393	100	4	16

● **3-KEY DIGITAL DEPTH GAUGE**  
3按键电子数显深度尺

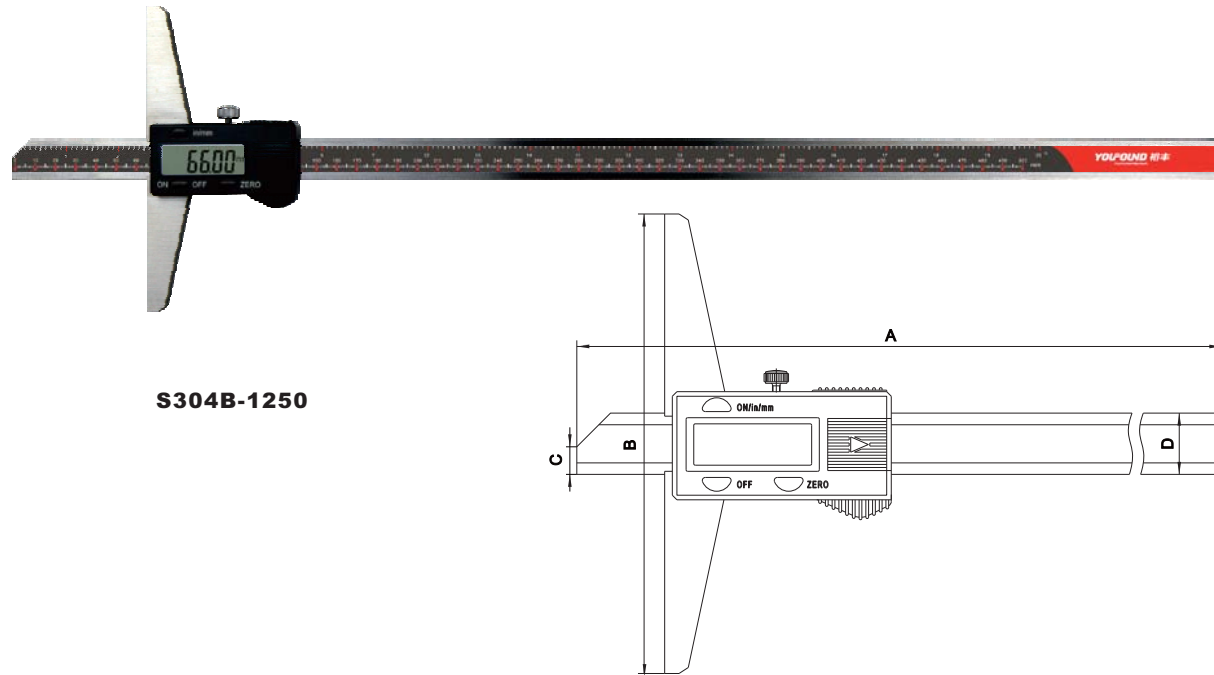

**S304B-1250**

● **Features 特性**

- DIN 862**  
 DIN862  
 DIN862标准
- 11mm**  
 Number size 11mm  
 11mm字高
- 0**  
 Arbitrary set zero  
 任意位置置零
- MM IN**  
 MM-IN  
 公英制转换
- 1.5**  
 Max moving speed 1.5m/s  
 最大移动速度 1.5米/秒
- ◆**  
 Stainless Hardened  
 不锈钢淬硬

● **Optional features 可选功能**

- Normal**  
 常规量面
- With Hook**  
 单勾头
- Double Hook**  
 双勾头
- Pin**  
 针头
- Normal 2**  
 圆弧量面
- USB**  
 USB 模式接口
- 3**  
 Max moving speed 3m/s  
 最大移动速度 3米/秒
- Auto off**  
 自动断电 可选

	Specification 规格	QTY/CTN 装箱数量	N. W. /G. W. 净重/毛重 (kg)	Meas(cm) 外箱尺寸	A	B	C	D
S304B.WK-1245	0-450mm*0.01/0-18in*0.0005	10	15.5/18	71*19.5*15.5	545	150	9	16
S304B.WK-1250	0-500mm*0.01/0-20in*0.0005	10	17.5/20	81*19.5*15.5	595	150	9	16
S304B.WK-1260	0-600mm*0.01/0-24in*0.0005	10	19.3/21.8	81*19.5*15.5	695	150	9	16

● **FLAT-HEAD EXTERNAL GROOVE DIGITAL CALIPER**  
外沟槽电子数显卡尺

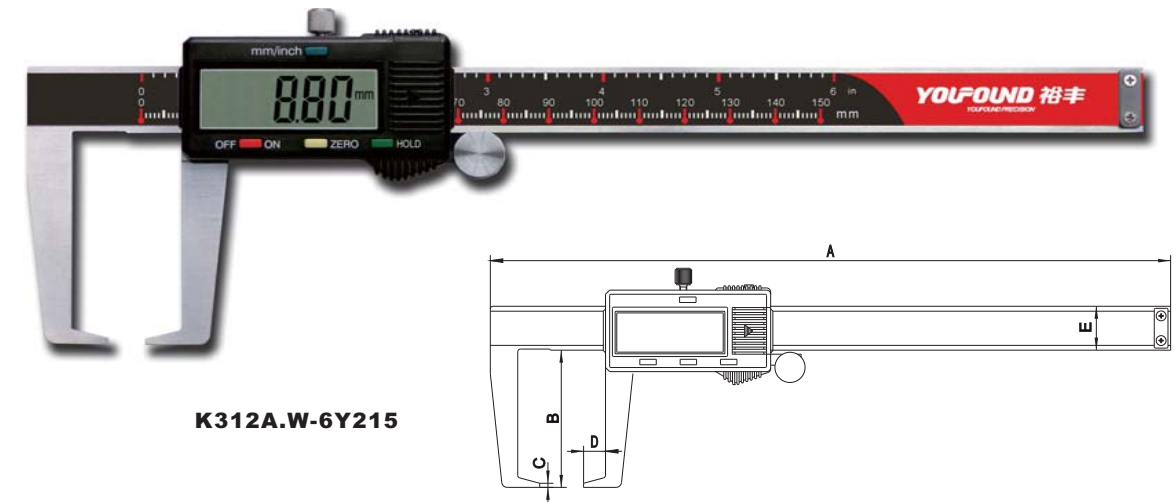

**K312A.W-6Y215**

● **Features 特性**

- External groove measuring  
外沟槽测量专用
  - MPE=30μm ≤200mm; MPE=40μm >200mm  
最大允许误差: 30μm ≤200mm; 40μm >200mm
  - Display number Size 11mm  
显示数字高度11mm
  - Zero setting at any position  
任意位置置零
  - Max moving speed 1.5m/s  
最大响应速度1.5m/s
- Metric/Inch system interchange  
公英制转换
  - Hold function  
数据保持功能
  - Stainless Hardened  
不锈钢淬硬

	Specification 规格	QTY/CTN 装箱数量	N. W. /G. W. 净重/毛重 (kg)	Meas(cm) 外箱尺寸	A	B	C	D	E
K312A.W-6Y210	0-100mm*0.01/0-4in*0.0005				200	50	1.5	8	16
K312A.W-6Y215	0-150mm*0.01/0-6in*0.0005				248	50	1.5	8	16
K312A.W-6Y220	0-200mm*0.01/0-8in*0.0005				300	50	1.5	8	16
K312A.W-6Y230	0-300mm*0.01/0-12in*0.0005				400	50	1.5	8	16

● **FLAT-HEAD EXTERNAL GROOVE DIGITAL CALIPER**  
外沟槽电子数显卡尺

K312A.W-7Y210

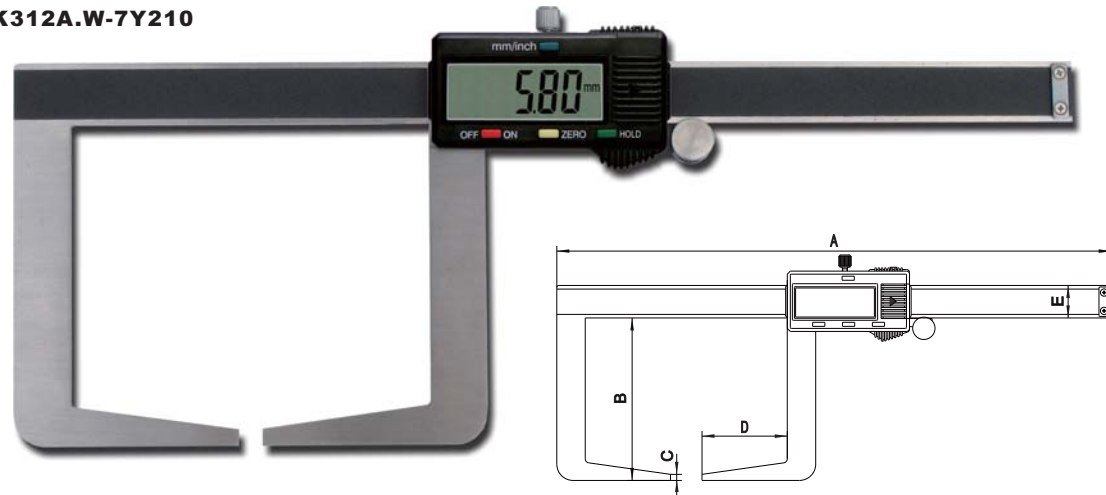

● **Features 特性**

- External groove measuring  
外沟槽测量专用
- MPE=40μm ≤200mm; MPE=50μm >200mm  
最大允许误差: 40μm ≤200mm; 50μm >200mm
- Display number size 11mm  
显示数字高度11mm
- Zero setting at any position  
任意位置置零
- Max moving speed 1.5m/s  
最大响应速度1.5m/s
- Metric/Inch system interchange  
公英制转换
- Hold function  
数据保持功能
- Stainless Hardened  
不锈钢淬硬

	Specification 规格	QTY/CTN 装箱数量	N. W. /G. W. 净重/毛重 (kg)	Meas(cm) 外箱尺寸	A	B	C	D	E
K312A.W-7Y210	0-100mm*0.01/0-4in*0.0005				267	80	4	42	16
K312A.W-7Y215	0-150mm*0.01/0-6in*0.0005				317	80	4	42	16
K312A.W-7Y220	0-200mm*0.01/0-8in*0.0005				370	80	4	42	16
K312A.W-7Y230	0-300mm*0.01/0-12in*0.0005				470	80	4	42	16

● **INNER GROOVE DIGITAL CALIPER**  
内沟槽电子数显卡尺

K312A.W-6Y115

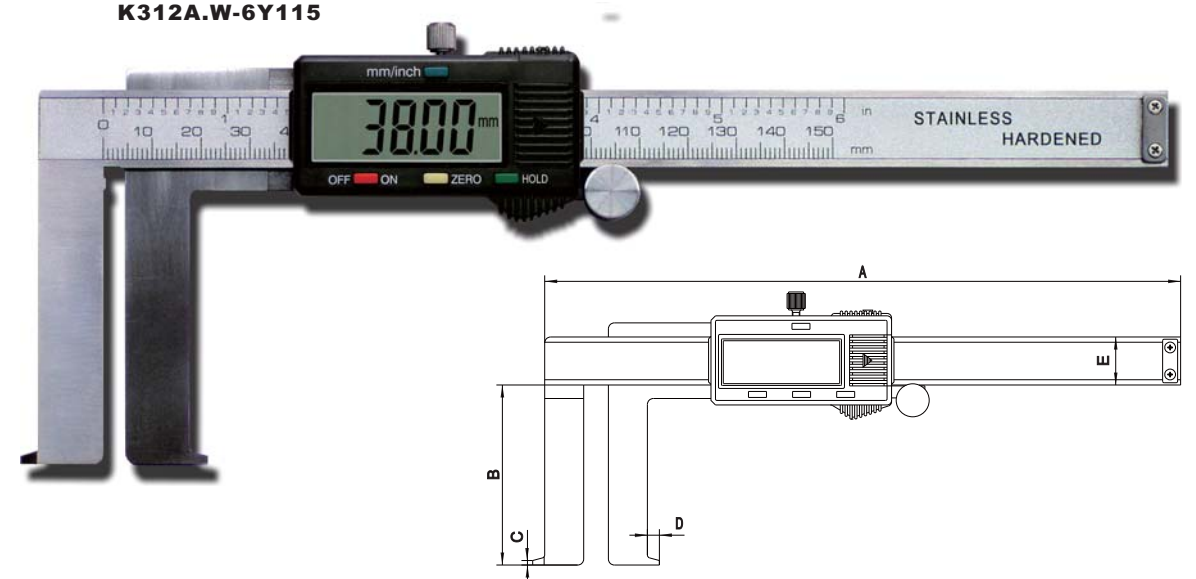

● **Features 特性**

- Inner groove measuring  
内沟槽测量专用
- MPE=40μm ≤200mm; MPE=50μm >200mm  
最大允许误差: 40μm ≤200mm; 50μm >200mm
- Display number Size 11mm  
显示数字高度11mm
- Zero setting at any position  
任意位置置零
- Max moving speed 1.5m/s  
最大响应速度1.5m/s
- Metric/Inch system interchange  
公英制转换
- Hold function  
数据保持功能
- Stainless Hardened  
不锈钢淬硬

	Specification 规格	QTY/CTN 装箱数量	N. W. /G. W. 净重/毛重 (kg)	Meas(cm) 外箱尺寸	A	B	C	D	E
K312A.W-6Y110	0-100mm*0.01/0-4in*0.0005				183	60	1.5	4	16
K312A.W-6Y115	0-150mm*0.01/0-6in*0.0005				233	60	1.5	4	16
K312A.W-6Y120	0-200mm*0.01/0-8in*0.0005				288	60	1.5	4	16
K312A.W-6Y130	0-300mm*0.01/0-12in*0.0005				388	60	1.5	4	16

● **INNER GROOVE DIGITAL CALIPER**  
内沟槽电子数显卡尺

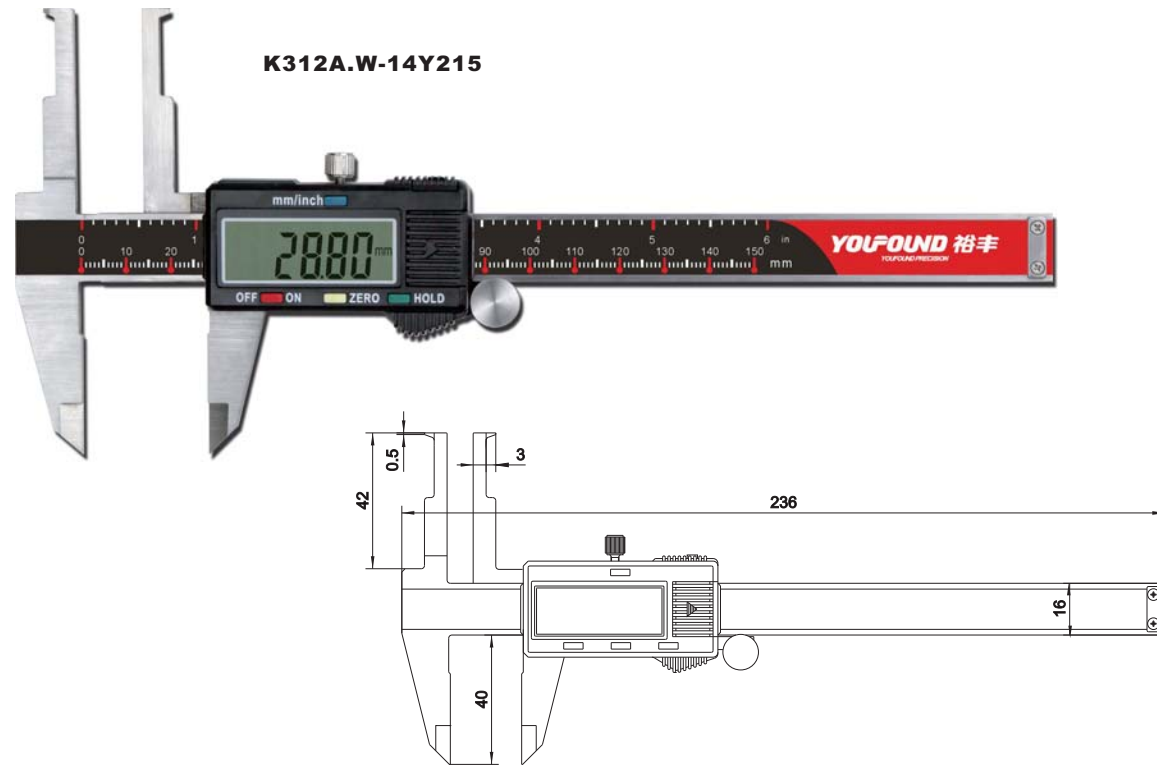

● **Features 特性**

- Inner groove measuring. With outside measuring jaws  
内沟槽测量专用。附带外测量爪
- Specification: 0-150mm\*0.01/0-6in\*0.0005  
规格: 0-150mm\*0.01/0-6in\*0.0005
- MPE=40 $\mu$ m  $\leq$ 200mm; MPE=50 $\mu$ m >200mm  
最大允许误差: 40 $\mu$ m  $\leq$ 200mm; 50 $\mu$ m >200mm
- Display number size 11mm  
显示数字高度11mm
- Zero setting at any position  
任意位置置零
- Max moving speed 1.5m/s  
最大响应速度1.5m/s
- Metric/Inch system interchange  
公英制转换
- Hold function  
数据保持功能
- Stainless Hardened  
不锈钢淬硬

● **MINI INNER GROOVE DIGITAL CALIPER**  
迷你内沟槽电子数显卡尺

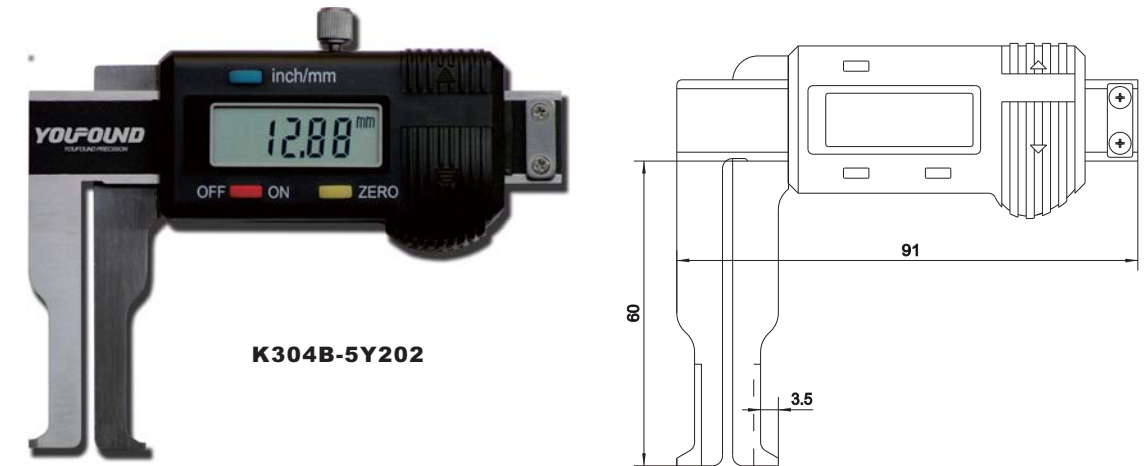

● **Features 特性**

- Inner groove measuring. with block for 0 setting  
内沟槽测量专用，附带对0块
- Specification: 0-150mm\*0.01/0-6in\*0.0005  
规格: 0-150mm\*0.01/0-6in\*0.0005
- MPE=20 $\mu$ m  
最大允许误差: 20 $\mu$ m
- Display number size 8mm  
显示数字高度8mm
- Max moving speed 1.5m/s  
最大响应速度1.5m/s
- Metric/Inch system interchange  
公英制转换
- Stainless Hardened  
不锈钢淬硬
- Manual power ON/OFF or Auto power OFF  
手动断电/自动断电可选

● **SUPER JAWS INSIDE CALIPER**  
超长爪内径电子数显卡尺

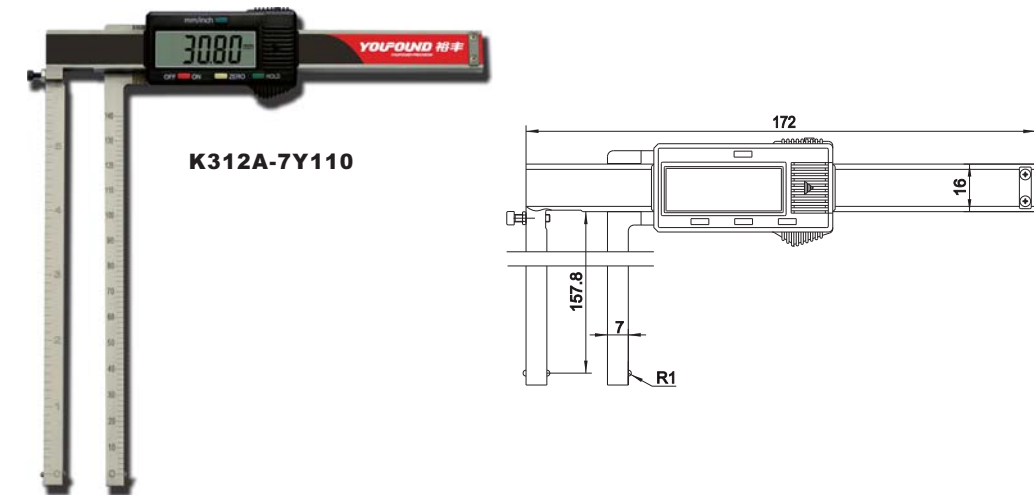

● **Features 特性**

- Depth hole Measuring. Automatic limit force design  
内沟槽测量专用，自动限力设计
- Specification: 0-100mm\*0.01/0-4in\*0.0005  
规格: 0-100mm\*0.01/0-4in\*0.0005
- MPE=80 $\mu$ m  
最大允许误差: 80 $\mu$ m
- Display Number Size 11mm  
显示数字高度11mm
- Max moving speed 1.5m/s  
最大响应速度1.5m/s
- Metric/Inch system interchange, with HOLD function  
公英制转换，带数据保持功能
- Stainless Hardened  
不锈钢淬硬

● **CENTER DISTANCE MEASURING DIGITAL CALIPER**  
中心距电子数显卡尺

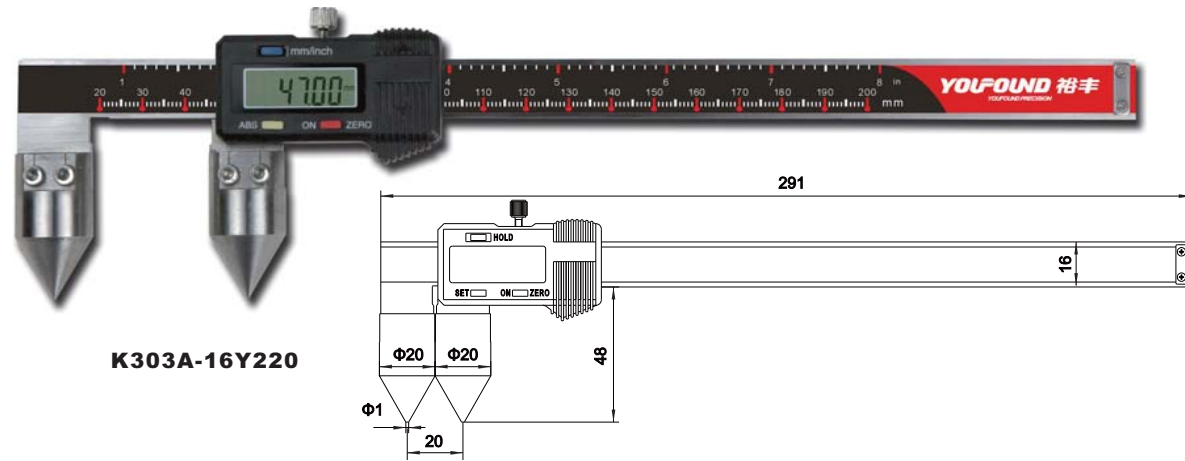

● **EDGE DISTANCE MEASURING DIGITAL CALIPER**  
边距电子数显卡尺

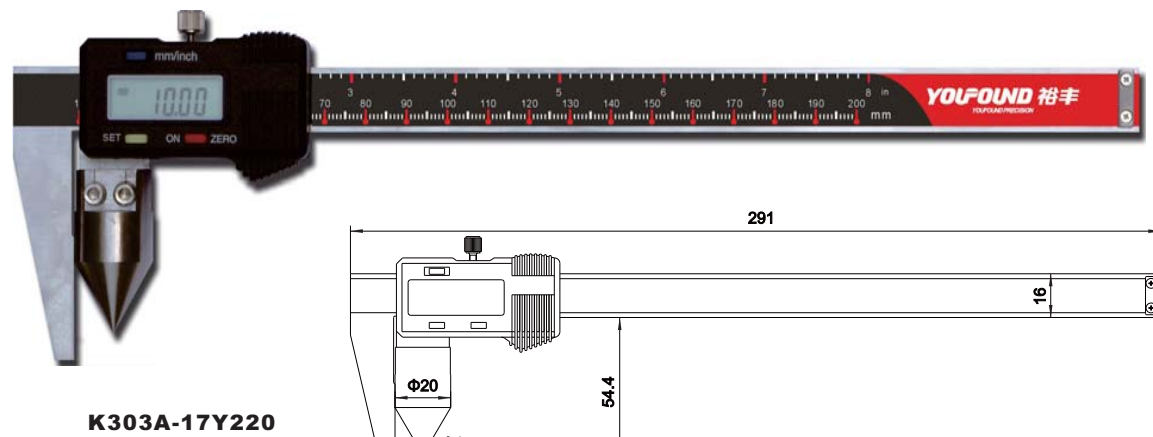

● **Features 特性**

- Measuring for center(edge) distance, with ZERO SET function  
用于孔中心距(孔边距)测量,带预置数功能
- Specification: 20(10)-200mm\*0.01/0.8(0.4)-8in\*0.0005  
规格: 20(10)-200mm\*0.01/0.8(0.4)-8in\*0.0005
- MPE=50μm  
最大允许误差: 50μm
- Display number size 11mm  
显示数字高度11mm
- Max moving speed 1.5m/s  
最大响应速度1.5m/s
- Metric/Inch system interchange  
公英制转换
- Stainless Hardened  
不锈钢淬硬
- Auto power OFF  
自动断电

● **EDGE DISTANCE MEASURING VERNIER CALIPER**  
边距游标卡尺

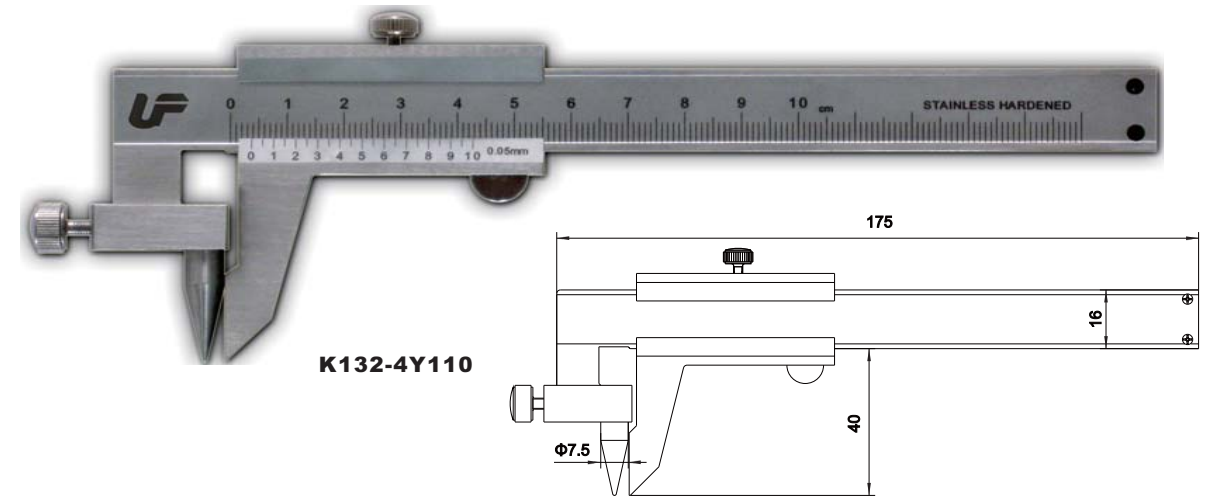

● **Features 特性**

- Measuring for edge distance, Direct reading  
用于孔中心到边距测量,直接读数。
- Specification: 4-100mm\*0.05  
规格: 4-100mm\*0.05
- MPE=90μm  
最大允许误差: 90μm
- Mono Block  
整体游标
- Laser Marking  
激光刻线
- Stainless Hardened  
不锈钢淬硬

● **VERNIER CALIPER WITH LONG INNER JAW**  
长内爪游标卡尺

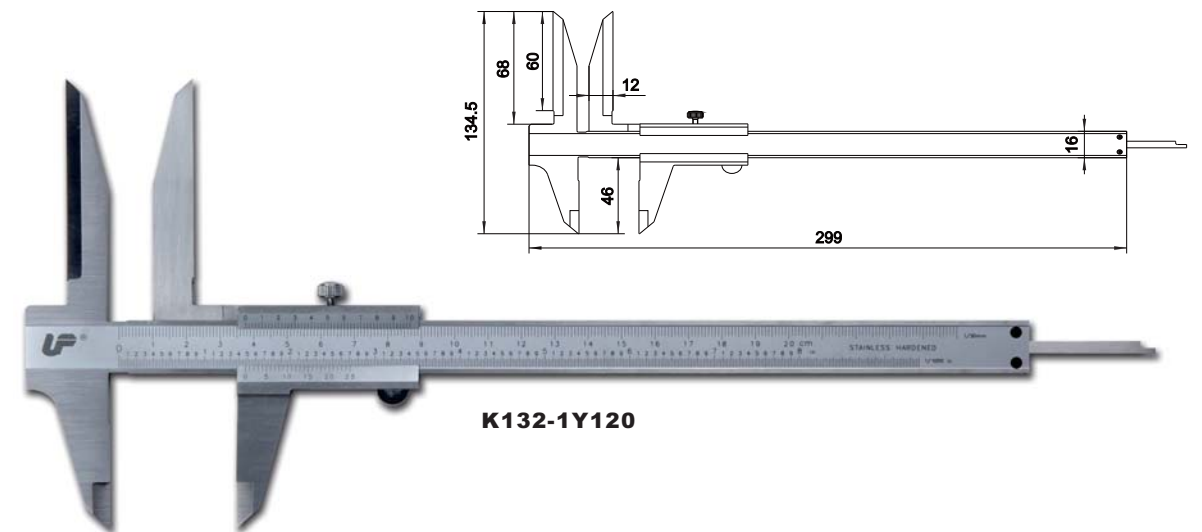

● **Features 特性**

- Long Inner Jaws  
长内量爪设计
- Specification: 0-200mm\*0.02/0-8in\*0.001  
规格: 0-200mm\*0.02/0-8in\*0.001
- MPE=50μm  
最大允许误差: 50μm
- Mono Block  
整体游标
- Laser Marking  
激光刻线
- Stainless Hardened  
不锈钢淬硬

● **GLASS CUTTING DIGITAL CALIPER**

玻璃切割卡尺

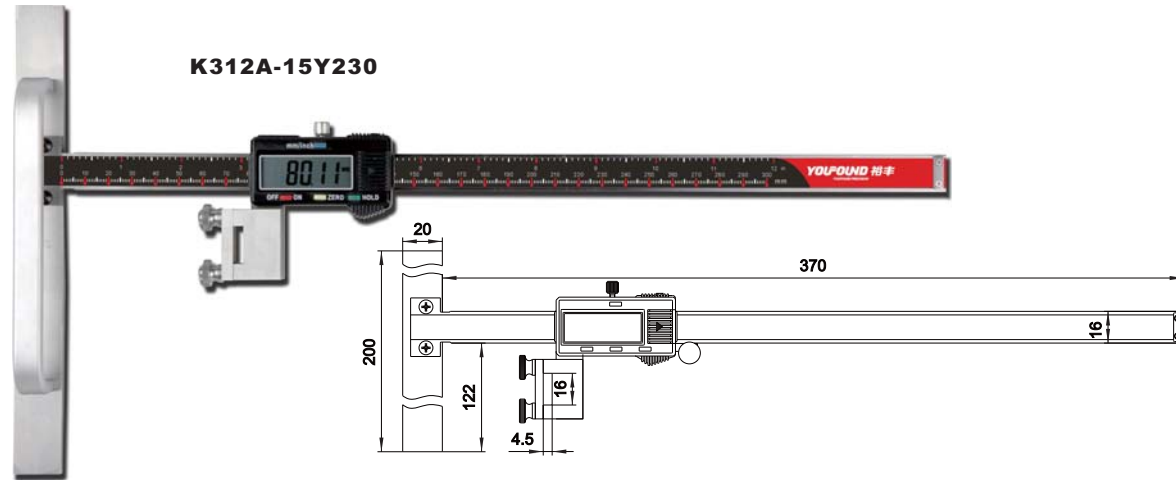

● **Features 特性**

- For glass cutting and marking  
用于玻璃切割及画线
- Specification: 0-300mm\*0.01/0-12in\*0.0005  
规格: 0-300mm\*0.01/0-12in\*0.0005
- Display number size 11mm  
显示数字高度11mm
- Zero setting at any position  
任意位置置零
- Max moving speed 1.5m/s  
最大响应速度1.5m/s
- Metric/Inch system interchange, with HOLD function  
公英制转换, 带数据保持功能
- Stainless Hardened  
不锈钢淬硬

● **VERNIER CALIPER FOR DENTIST**

游标牙医卡尺

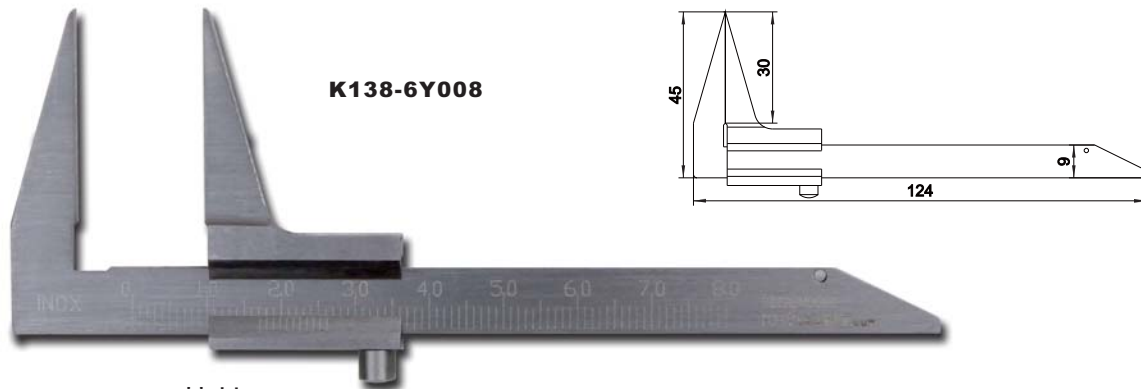

● **Features 特性**

- For Dentist  
用于牙医工作
- Specification: 0-80mm\*0.1  
规格: 0-80mm\*0.1
- Mono Block  
整体设计
- Laser Marking  
激光刻线
- Stainless  
不锈钢制造

● **GROOVE MEASURING DEPTH GAUGE**

沟槽深度尺

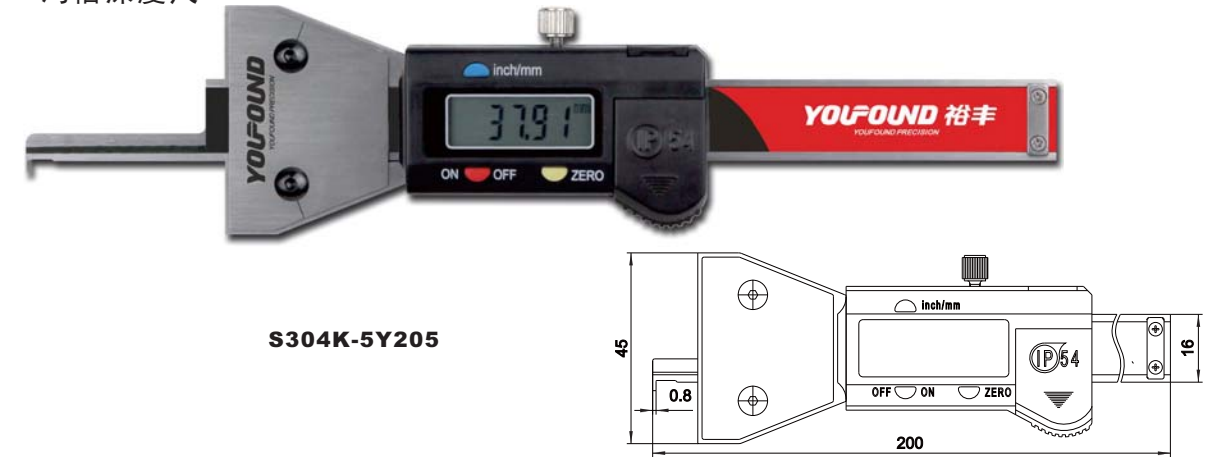

● **Features 特性**

- For Depth of The Inner Groove  
用于内沟槽深度测量
- Specification: 0-50mm\*0.01/0-2in\*0.0005  
规格: 0-50mm\*0.01/0-2in\*0.0005
- Display number size 8mm  
显示数字高度8mm
- Zero setting at any position  
任意位置置零
- Max moving speed 1.5m/s  
最大响应速度1.5m/s
- Metric/Inch system interchange  
公英制转换
- Stainless Hardened  
不锈钢淬硬
- Ip54  
Ip54防护

● **DEPTH GAUGE WITH HOLES**

深度尺

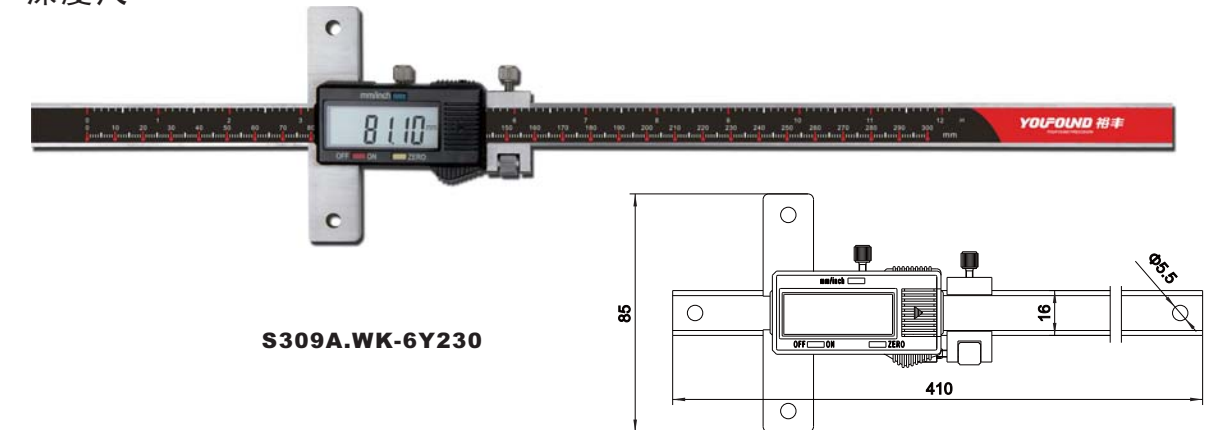

● **Features 特性**

- Specification: 0-300mm\*0.01/0-12in\*0.0005  
规格: 0-300mm\*0.01/0-12in\*0.0005
- MPE=40μm  
最大允许误差: 40μm
- Display number size 11mm  
显示数字高度11mm
- Zero setting at any position  
任意位置置零
- Max moving speed 1.5m/s  
最大响应速度1.5m/s
- Metric/Inch system interchange  
公英制转换
- Stainless Hardened  
不锈钢淬硬
- Manual power ON/OFF or Auto power OFF  
手动断电/自动断电可选

● **DEPTH GAUGE**  
特殊深度尺

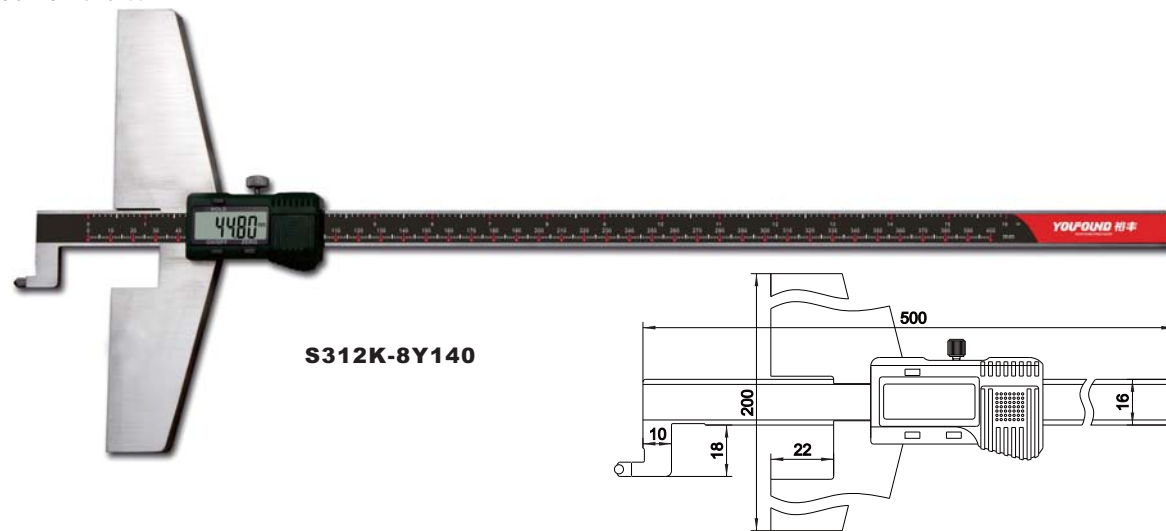

● **Features 特性**

- Specification: 0-400mm\*0.01  
规格: 0-400mm\*0.01
- MPE=50μm  
最大允许误差: 50μm
- Display number size 11mm  
显示数字高度11mm
- Zero setting at any position  
任意位置置零
- Max moving speed 3m/s  
最大响应速度3m/s
- Hold function  
数据保持功能
- Stainless Hardened  
不锈钢淬硬
- Manual power ON/OFF or Auto power OFF  
手动断电/自动断电可选

● **WELDING RULES**  
焊缝规

S312A-9Y2015

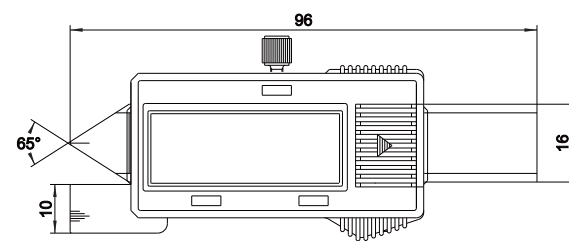

● **Features 特性**

- Welding measuring  
焊缝测量
- Specification: 0-15mm\*0.01/0-0.6in\*0.0005  
规格: 0-15mm\*0.01/0-0.6in\*0.0005
- MPE=30μm  
最大允许误差: 30μm
- Display number size 11mm  
显示数字高度11mm
- Zero setting at any position  
任意位置置零
- Metric/Inch system interchange, with HOLD function  
公英制转换, 带数据保持功能
- Stainless Hardened  
不锈钢淬硬

● **DEPTH GAUGE**  
特殊深度尺

S312K-10Y202

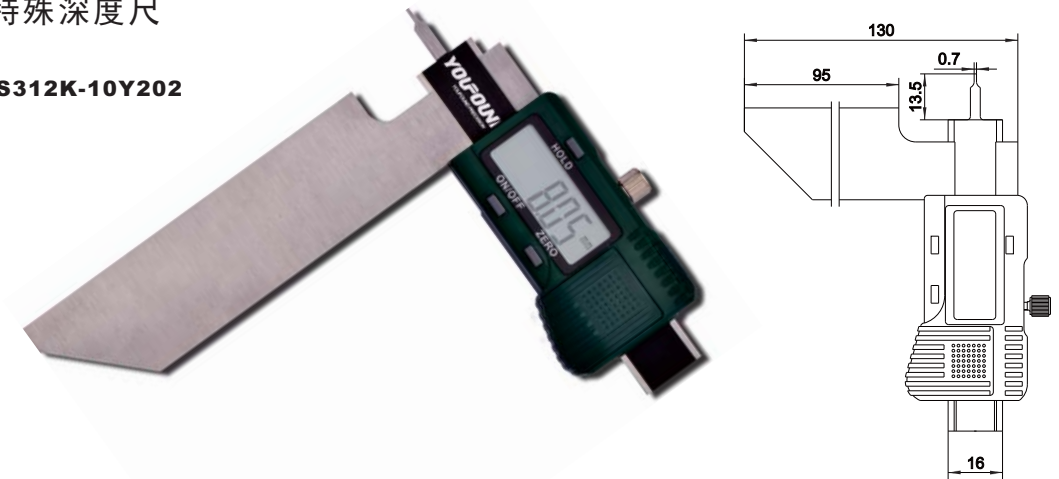

● **Features 特性**

- Special measuring  
特殊位置深度测量
- Specification: 0-20mm\*0.01  
规格: 0-20mm\*0.01
- MPE=30μm  
最大允许误差: 30μm
- Display number size 11mm  
显示数字高度11mm
- Zero setting at any position  
任意位置置零
- HOLD function  
带数据保持功能
- Stainless Hardened  
不锈钢淬硬

● **DEPTH GAUGE**  
园杆深度尺

S312K.WK-11Y225

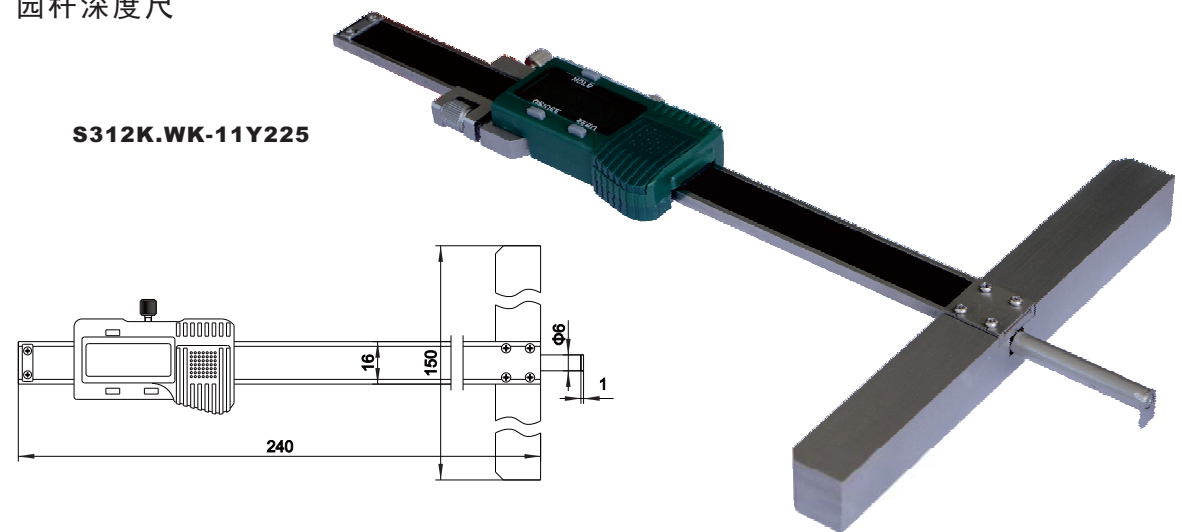

● **Features 特性**

- Special measuring  
小孔深度及沟槽测量
- Specification: 0-250mm\*0.01  
规格: 0-250mm\*0.01
- MPE=40μm  
最大允许误差: 40μm
- Display number size 11mm  
显示数字高度11mm
- Zero setting at any position  
任意位置置零
- HOLD function  
带数据保持功能
- Stainless Hardened  
不锈钢淬硬

● **T CALIPER**  
T型划线卡尺

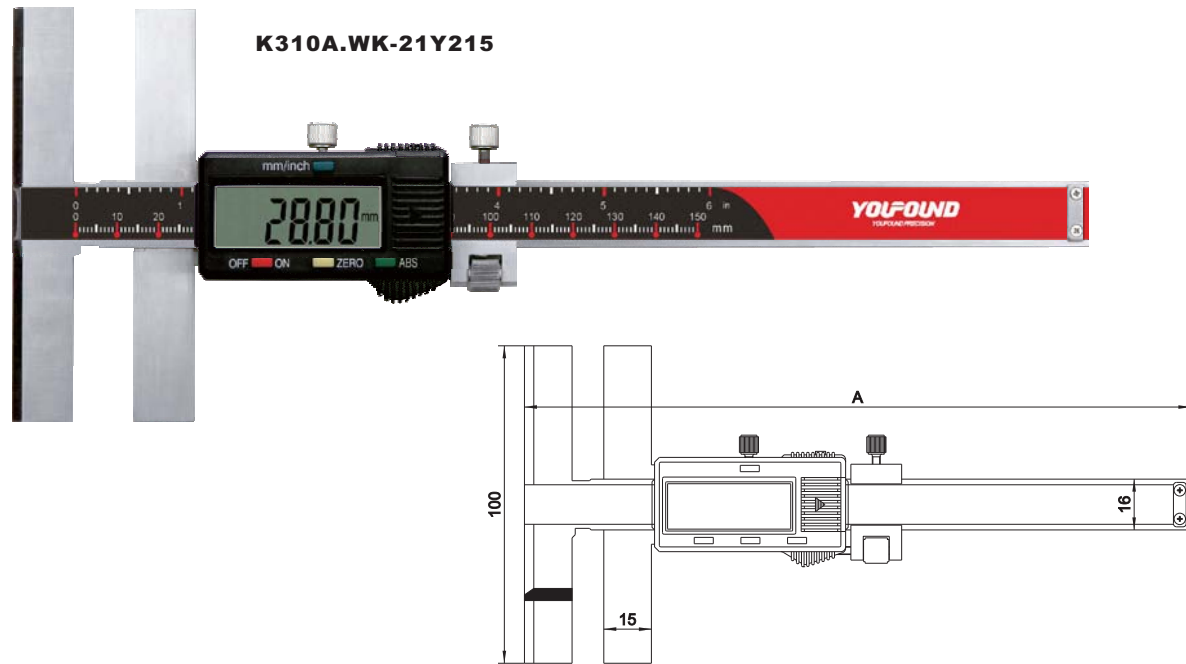

● **Features 特性**

- For Marking and Measuring  
划线及测量
- MPE=50μm  
最大允许误差: 50μm
- Display Number Size 11mm  
显示数字高度11mm
- Zero setting at any position  
任意位置置零
- ABS Function  
带数据保持功能
- Stainless Hardened  
不锈钢淬硬

	Specification 规格	QTY/CTN 装箱数量	N. W. /G. W. 净重/毛重 (kg)	Meas(cm) 外箱尺寸	A
K310A.WK-21Y210	0-100mm*0.01/0-4in*0.0005				210
K310A.WK-21Y215	0-150mm*0.01/0-6in*0.0005				260
K310A.WK-21Y220	0-200mm*0.01/0-8in*0.0005				310
K310A.WK-21Y230	0-300mm*0.01/0-12in*0.0005				415

● **BRAKE DISC CALIPERS**  
刹车盘卡尺



● **Features 特性**

- For Brake Disc  
刹车盘测量专用
- Specification: 0-60mm\*0.01/0-2.4in\*0.0005  
规格: 0-60mm\*0.01/0-2.4in\*0.0005
- MPE=40μm  
最大允许误差: 40μm
- Display number size 11mm  
显示数字高度11mm
- Zero setting at any position  
任意位置置零
- Max moving speed 1.5m/s  
最大响应速度1.5m/s
- Metric/Inch system interchanges, with HOLD Function  
公英制转换, 带数据保持功能
- Stainless Hardened  
不锈钢淬硬

● **BRAKE DISC CALIPERS**  
刹车盘卡尺

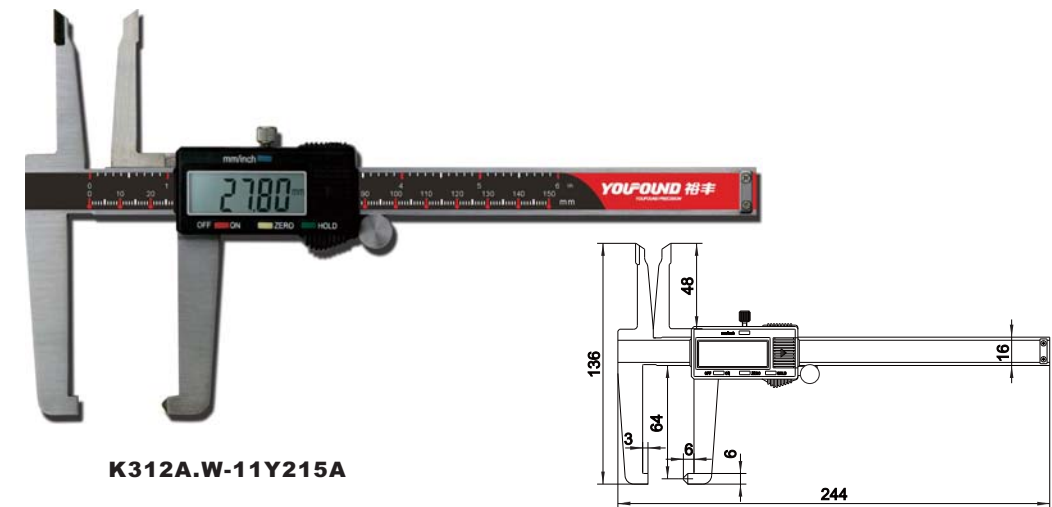

● **Features 特性**

- For Brake Disc and Brake Pad  
刹车盘及刹车片测量专用
- Specification: 0-150mm\*0.01/0-6in\*0.0005  
规格: 0-150mm\*0.01/0-6in\*0.0005
- MPE=50μm  
最大允许误差: 50μm
- Display number size 11mm  
显示数字高度11mm
- Zero setting at any position  
任意位置置零
- Max moving speed 1.5m/s  
最大响应速度1.5m/s
- Metric/Inch system interchange, with HOLD Function  
公英制转换, 带数据保持功能
- Stainless Hardened  
不锈钢淬硬

● **BRAKE DISC CALIPER**  
刹车盘卡尺

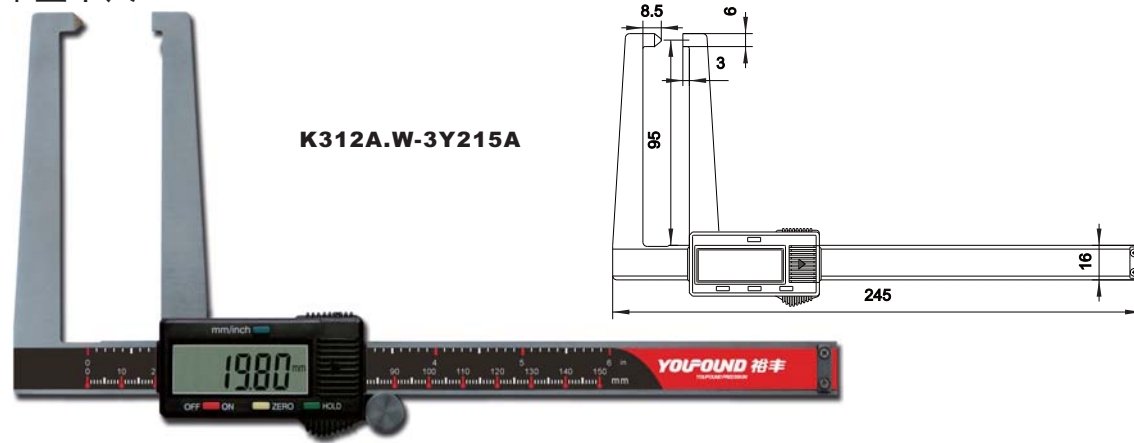

● **Features 特性**

- For Brake Disc 刹车盘测量专用
- Specification: 0-150mm\*0.01/0-6in\*0.0005 规格: 0-150mm\*0.01/0-6in\*0.0005
- MPE=50μm 最大允许误差: 50μm
- Display number size 11mm 显示数字高度11mm
- Zero setting at any position 任意位置置零
- Max moving speed 1.5m/s 最大响应速度1.5m/s
- Metric/Inch system interchange, with HOLD Function 公英制转换, 带数据保持功能
- Stainless Hardened 不锈钢淬硬

● **BRAKE DISC CALIPER**  
刹车盘卡尺

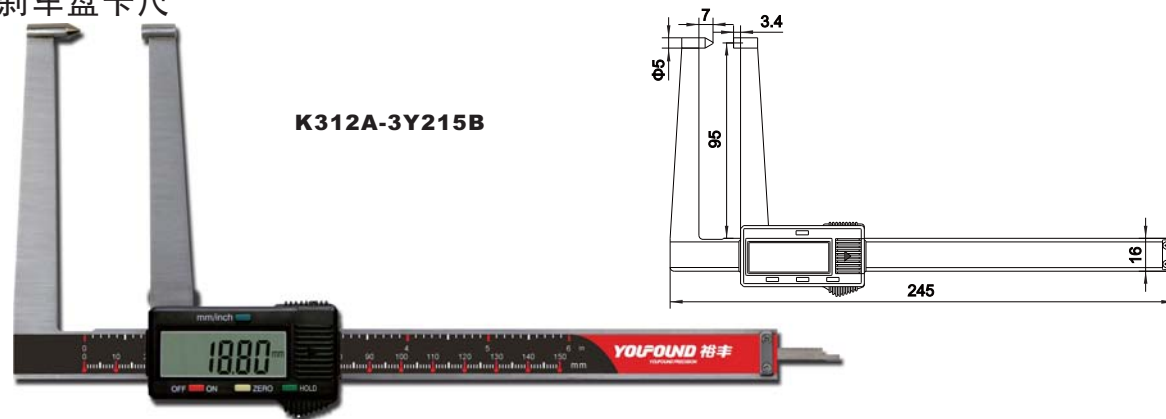

● **Features 特性**

- For Brake Disc 刹车盘测量专用
- Specification: 0-150mm\*0.01/0-6in\*0.0005 规格: 0-150mm\*0.01/0-6in\*0.0005
- MPE=50μm 最大允许误差: 50μm
- Display number size 11mm 显示数字高度11mm
- Zero setting at any position 任意位置置零
- Max moving speed 1.5m/s 最大响应速度1.5m/s
- Metric/Inch system interchange, with HOLD Function 公英制转换, 带数据保持功能
- Stainless Hardened 不锈钢淬硬

● **BRAKE DISC CALIPER**  
刹车盘卡尺

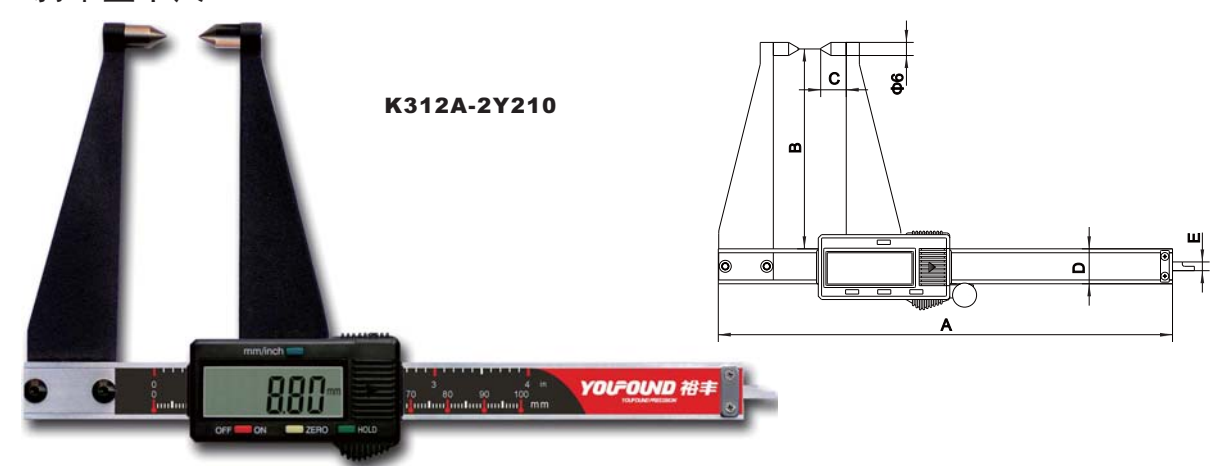

	Specification 规格	QTY/CTN 装箱数量	N. W. /G. W. 净重/毛重(kg)	Meas(cm) 外箱尺寸	A	B	C	D	E
K312A-2Y210	0-100mm*0.01/0-4in*0.0005				208	91.5	11.5	16	4
K312A-2Y215	0-150mm*0.01/0-6in*0.0005				258	91.5	11.5	16	4
K312A-2Y220	0-200mm*0.01/0-8in*0.0005				300	91.5	11.5	16	4

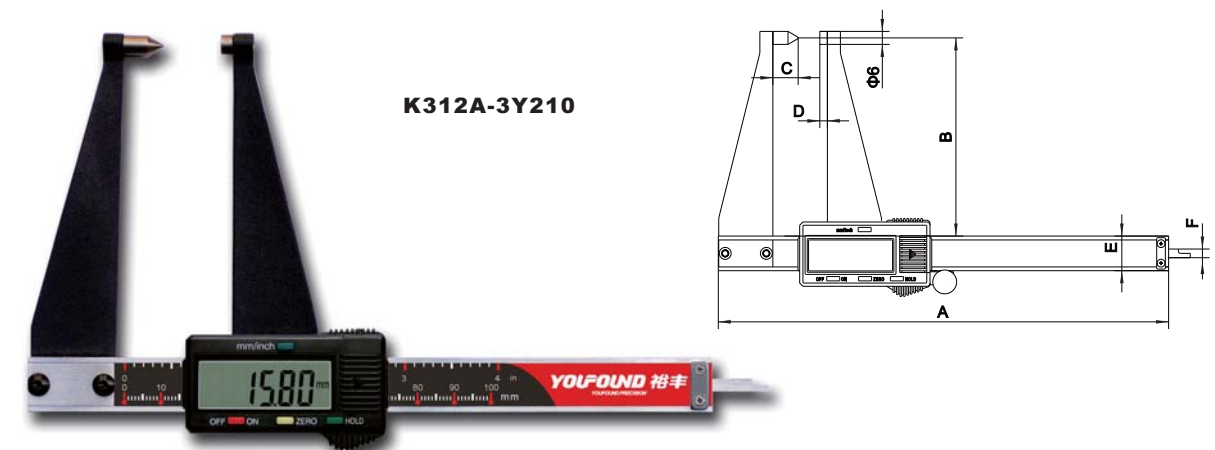

	Specification 规格	QTY/CTN 装箱数量	N. W. /G. W. 净重/毛重(kg)	Meas(cm) 外箱尺寸	A	B	C	D	E	F
K312A-3Y210	0-100mm*0.01/0-4in*0.0005				208	91.5	11.5	3.5	16	4
K312A-3Y215	0-150mm*0.01/0-6in*0.0005				258	91.5	11.5	3.5	16	4
K312A-3Y220	0-200mm*0.01/0-8in*0.0005				300	91.5	11.5	3.5	16	4

● **Features 特性**

- For Brake Disc, with Depth Rod 刹车盘测量专用
- Specification: 0-150mm\*0.01/0-6in\*0.0005 规格: 0-150mm\*0.01/0-6in\*0.0005
- MPE=50μm 最大允许误差: 50μm
- Display Number Size 11mm 显示数字高度11mm
- Zero setting at any position 任意位置置零
- Max moving speed 1.5m/s 最大响应速度1.5m/s
- Metric/Inch system interchange, with HOLD Function 公英制转换, 带数据保持功能

● **BREAK DRUM CALIPER**  
刹车鼓卡尺

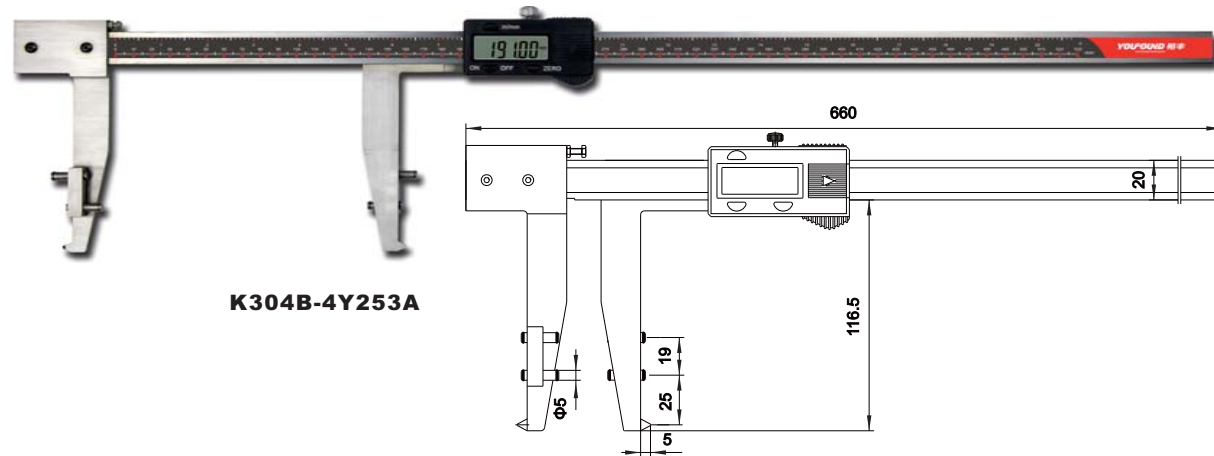

K304B-4Y253A

● **Features 特性**

- For Brake Drum, with Locating Device  
刹车鼓测量专用, 带定位装置
- Specification: 0-530mm\*0.01/0-20.8in\*0.0005  
规格: 0-530mm\*0.01/0-20.8in\*0.0005
- MPE=80μm  
最大允许误差: 80μm
- Display number size 11mm  
显示数字高度11mm
- Zero setting at any position  
任意位置置零
- Max moving speed 1.5m/s  
最大响应速度1.5m/s
- Metric/Inch system interchange  
公英制转换
- Stainless Hardened  
不锈钢淬硬

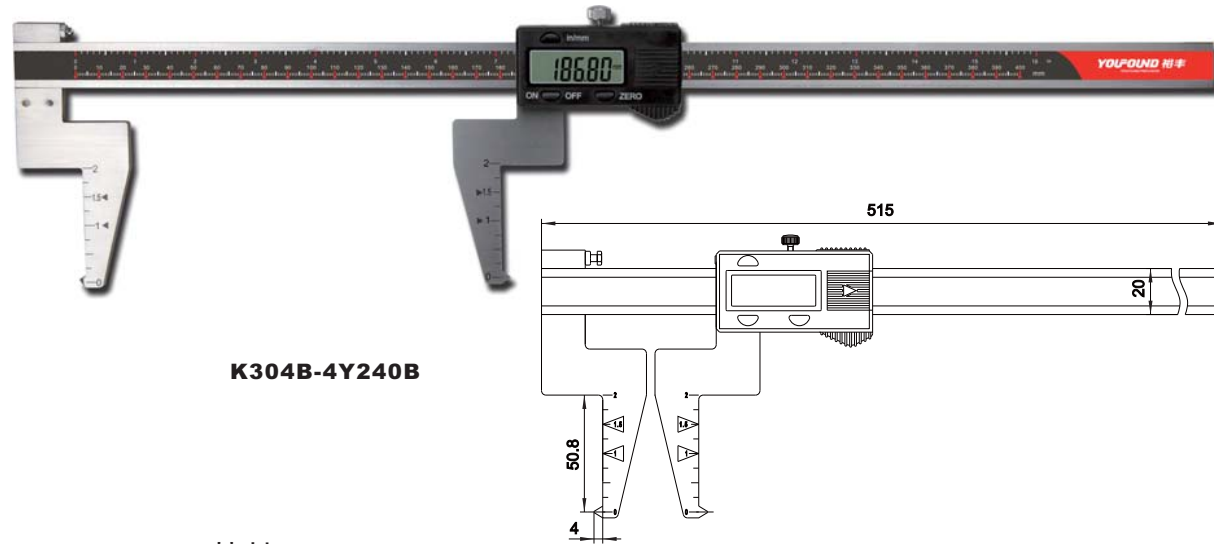

K304B-4Y240B

● **Features 特性**

- For Brake Drum, with Scale  
刹车鼓测量专用, 带深度刻度
- Specification: 0-400mm\*0.01/0-16in\*0.0005  
规格: 0-400mm\*0.01/0-16in\*0.0005
- MPE=80μm  
最大允许误差: 80μm
- Display number size 11mm  
显示数字高度11mm
- Zero setting at any position  
任意位置置零
- Max moving speed 1.5m/s  
最大响应速度1.5m/s
- Metric/Inch system interchange  
公英制转换
- Stainless Hardened  
不锈钢淬硬

● **BREAK DRUM CALIPER**  
刹车鼓卡尺

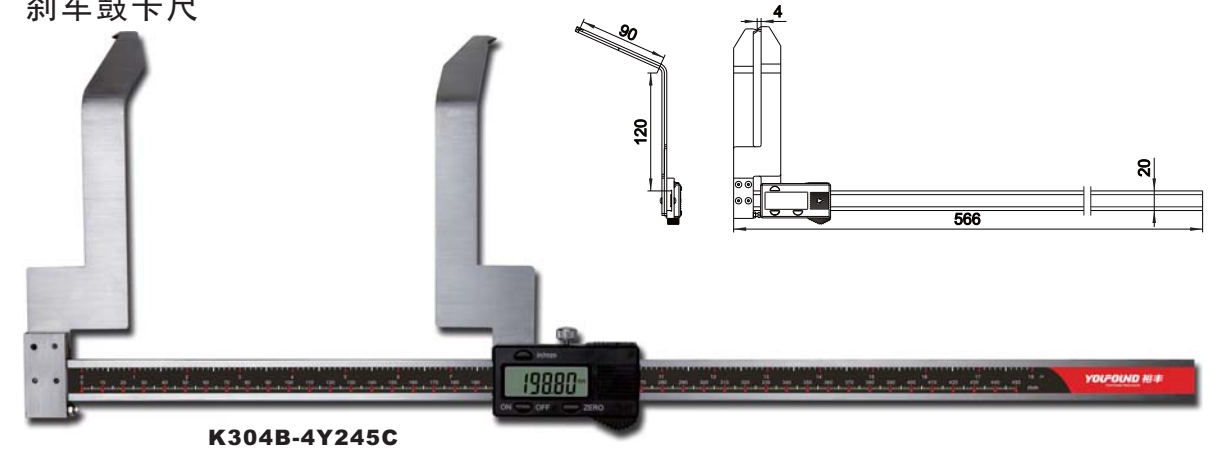

K304B-4Y245C

● **Features 特性**

- For Brake Drum, with Bending Jaws  
刹车鼓测量专用, 弯曲量爪
- Specification: 0-450mm\*0.01/0-18in\*0.0005  
规格: 0-450mm\*0.01/0-18in\*0.0005
- MPE=80μm  
最大允许误差: 80μm
- Display number size 11mm  
显示数字高度11mm
- Zero setting at any position  
任意位置置零
- Max moving speed 1.5m/s  
最大响应速度1.5m/s
- Metric/Inch system interchange  
公英制转换
- Stainless Hardened  
不锈钢淬硬

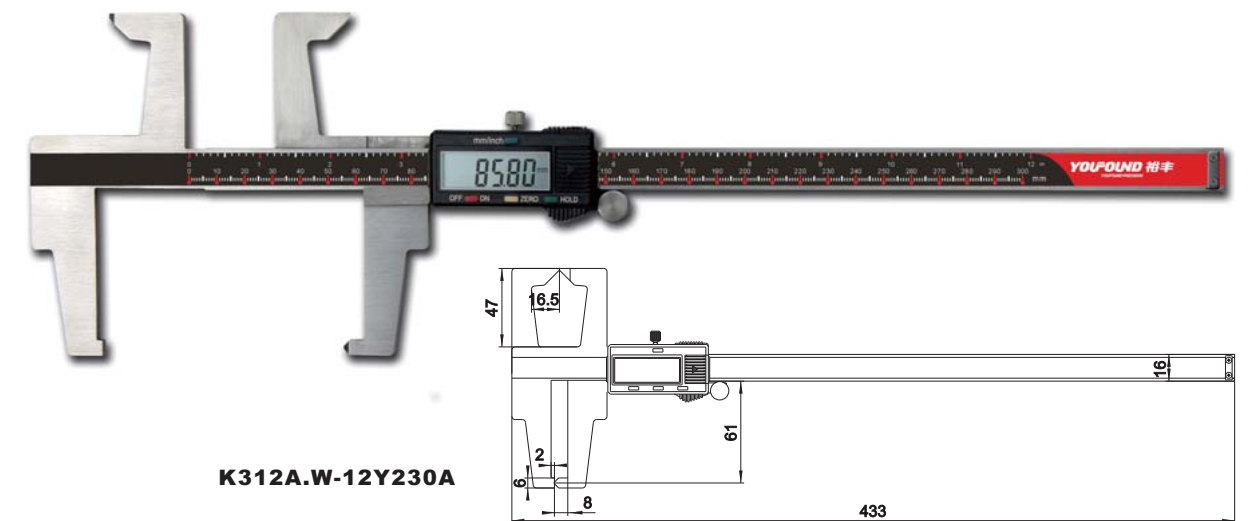

K312A.W-12Y230A

● **Features 特性**

- For Brake Drum and Brake Disc  
刹车鼓、刹车盘测量专用
- Specification: 0-300mm\*0.01/0-12in\*0.0005  
规格: 0-300mm\*0.01/0-12in\*0.0005
- MPE=50μm  
最大允许误差: 50μm
- Display number size 11mm  
显示数字高度11mm
- Zero setting at any position  
任意位置置零
- Max moving speed 1.5m/s  
最大响应速度1.5m/s
- Metric/Inch system interchange, with HOLD Function  
公英制转换, 带数据保持功能
- Stainless Hardened  
不锈钢淬硬

● **TREAD DEPTH GAUGE**  
胎纹深度尺



S312A-3Y202A

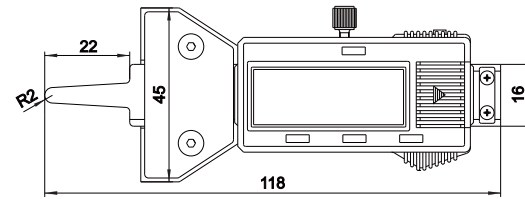

S312A-3Y202B

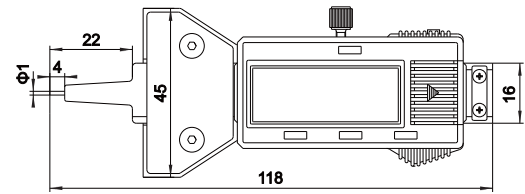

● **Features 特性**

- For Tire Measuring  
胎纹深度测量
- Specification: 0-25mm\*0.01/0-1in\*0.0005  
规格: 0-25mm\*0.01/0-1in\*0.0005
- MPE=30μm  
最大允许误差: 30μm
- Display number size 11mm  
显示数字高度11mm
- Zero setting at any position  
任意位置置零
- Max moving speed 1.5m/s  
最大响应速度1.5m/s
- Metric/Inch system interchange, with HOLD Function  
公英制转换, 带数据保持功能
- Stainless Hardened  
不锈钢淬硬



S309MX-4Y201

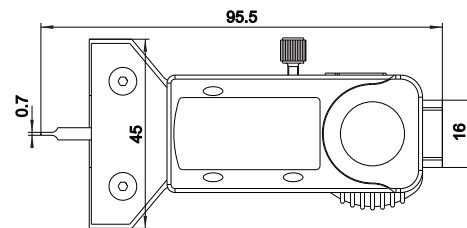

● **Features 特性**

- For Tire Measuring  
胎纹深度测量
- Specification: 0-10mm\*0.01/0-0.4in\*0.0005  
规格: 0-10mm\*0.01/0-0.4in\*0.0005
- MPE=10μm  
最大允许误差: 10μm
- Display number size 11mm  
显示数字高度11mm
- Zero setting at any position  
任意位置置零
- Max moving speed 1.5m/s  
最大响应速度1.5m/s
- Metric/Inch system interchange  
公英制转换
- Stainless Hardened  
不锈钢淬硬

● **TIRE GAUGE WITH DIGITAL TREAD DEPTH GAUGE**  
带数显胎纹深度尺胎压计



● **MINI TIRE GAUGE**  
胎压计



● **TIRE GAUGE WITH BACKLIGHT**  
带背光胎压计



● **TIRE GAUGE WITH TREAD DEPTH GAUGE**  
带胎纹深度尺胎压计



● **TIRE GAUGE WITH TREAD DEPTH GAUGE AND BACKLIGHT AND COMPASS**  
带胎纹深度尺、背光、指南针胎压计



● **Features 特性**

- Accuracy: ±1%  
精度: ±1%
- Operation Temp.: -5°C~50°C  
使用温度: -5°C~50°C
- CR2032 Button Cell  
Cr2032 纽扣电池
- Range: 0-100PSI, 0-7Bar, 0-7Kgf/cm², 0-700Kpa  
or 0-200PSI, 0-14Bar, 0-14Kgf/cm², 0-1400Kpa  
测量范围: 0-100PSI, 0-7Bar, 0-7Kgf/cm², 0-700Kpa  
或 0-200PSI, 0-14Bar, 0-14Kgf/cm², 0-1400Kpa
- Resolution: 0.1PSI, 0.01Bar, 0.01Kgf/cm², 1Kpa  
分辨率: 0.1PSI, 0.01Bar, 0.01Kgf/cm², 1Kpa

● **MICROMETER**  
千分尺



Q11025

● **Features 特性**

- Carbide Measuring Faces  
合金测量面
- Painted or Chrome-plated Frame  
烤漆或电镀尺架
- Ratchet Stop  
棘轮限力

	Specification 规格	QTY/CTN 装箱数量	N. W. /G. W. 净重/毛重 (kg)	Meas(cm) 外箱尺寸
Q11025	0-25mm*0.01	20	9.5/10.5	42*22*20
Q11050	25-50mm*0.01	20	11.5/12.5	47*24*19
Q11075	50-75mm*0.01	20	15/16	52*28*21
Q11100	75-100mm*0.01	20	18/19	59*32*20
Q12001	0-1in*0.001	20	9.5/10.5	42*22*20
Q12002	1-2in*0.001	20	11.5/12.5	47*24*19
Q12003	2-3in*0.001	20	15/16	52*28*21
Q12004	3-4in*0.001	20	18/19	59*32*20

● **DIGITAL MICROMETER**  
数显千分尺



Q23025



Q22025

● **Features 特性**

- Easy Operation  
使用简单
- Metric/Inch system interchange, with ABS function  
公英制转换, 带数据保持功能
- Carbide Measuring Faces  
合金测量面
- Ratchet Stop  
棘轮限力

	Specification 规格	QTY/CTN 装箱数量	N. W. /G. W. 净重/毛重 (kg)	Meas(cm) 外箱尺寸
Q22025	0-25mm*0.001/0-1in*0.00005	20	9.5/10.5	42*22*20
Q22050	25-50mm*0.001/1-2in*0.00005	20	11.5/12.5	47*24*19
Q22075	50-75mm*0.001/2-3in*0.00005	20	15/16	52*28*21
Q22100	75-100mm*0.001/3-4in*0.00005	20	18/19	59*32*20

● **DIAL INDICATORS**

百分表



● **Features 特性**

- Can be with or without back ear  
可配后耳盖
- Muilt-Diam of dial can be choose  
多种表圈直径
- The colors of dial can be designed by customers  
表圈及表盘颜色和款式可选

	Specification 规格	Dial Diam 表圈直径	QTY/CTN 装箱数量	N. W. /G. W. 净重/毛重(kg)	Meas(cm) 外箱尺寸
B0017-6010	0-10mm*0.1	60mm			
B0117-6015	0-15mm*0.1	60mm	50	9/11	47*30*22
B0117-6020	0-20mm*0.1	60mm	50	9/11	47*30*22
B0117-6030	0-30mm*0.1	60mm	50	9/11	47*30*22
B0113-3504	0-4mm*0.01	35mm	50	5/6	47*30*22
B0113-4003	0-3mm*0.01	40mm	50	5/6	34*30*22
B0113-4005	0-5mm*0.01	40mm	50	5/6	34*30*22
B0113-4008	0-8mm*0.01	40mm	50	5/6	34*30*22
B0113-4010	0-10mm*0.01	40mm	50	5/6	34*30*22
B0113-5503	0-3mm*0.01	55mm	50	9/11	47*30*22
B0113-5505	0-5mm*0.01	55mm	50	9/11	47*30*22
B0113-5510	0-10mm*0.01	55mm	50	9/11	47*30*22
B0113-6003	0-3mm*0.01	60mm	50	9/11	47*30*22
B0113-6005	0-5mm*0.01	60mm	50	9/11	47*30*22
B0113-6010	0-10mm*0.01	60mm	50	9/11	47*30*22
B0113-6015	0-15mm*0.01	60mm	50	9/11	47*30*22
B0113-6020	0-20mm*0.01	60mm	50	9/11	47*30*22
B0113-6025	0-25mm*0.01	60mm	50	9/11	47*30*22
B0113-6030	0-30mm*0.01	60mm	50	9/11	47*30*22
B0113-7635	0-35mm*0.01	76mm	50	22/24	50*46*33
B0113-7640	0-40mm*0.01	76mm	50	22/24	50*46*33
B0113-7645	0-45mm*0.01	76mm	50	22/24	50*46*33
B0113-7650	0-50mm*0.01	76mm	50	22/24	50*46*33
B0126-4001	0-0.1in*0.001	1.6in	50	5/6	34*22*20
B0126-4002	0-0.2in*0.001	1.6in	50	5/6	34*22*20
B0126-40025	0-0.25in*0.001	1.6in	50	5/6	34*22*20
B0126-55025	0-0.25in*0.001	2.17in	50	7/9	42*34*32
B0126-5505	0-0.5in*0.001	2.17in	50	7/9	42*34*32
B0126-5510	0-1in*0.001	2.17in	50	7/9	42*34*32
B0126-60025	0-0.25in*0.001	2.375in	50	7/9	42*34*32
B0126-6005	0-0.5in*0.001	2.375in	50	7/9	42*34*32
B0126-6010	0-1in*0.001	2.375in	50	7/9	42*34*32
B0126-7615	0-1.5in*0.001	3in	50	18/20	58*51*31

● **MICRON INDICATORS**

千分表



	Specification 规格	Dial Diam 表圈直径	QTY/CTN 装箱数量	N. W. /G. W. 净重/毛重(kg)	Meas(cm) 外箱尺寸
B0511-4001	0-150mm*0.01	40mm	50	7/8	34*22*20
B0511-6001	0-1mm*0.001	60mm	50	9/11	42*34*32
B0511-6002	0-2mm*0.001	60mm	50	9/11	42*34*32
B0511-6003	0-3mm*0.001	60mm	50	9/11	42*34*32
B0511-6005	0-5mm*0.001	60mm	50	9/11	42*34*32
B0511-7601	0-1mm*0.001	76mm	50	11/13	58*34*32
B0511-7602	0-2mm*0.001	76mm	50	11/13	58*34*32
B0511-7603	0-3mm*0.001	76mm	50	11/13	58*34*32
B0511-7605	0-5mm*0.001	76mm	50	11/13	58*34*32

● **TEST INDICATING DIALS**

杠杆百分表

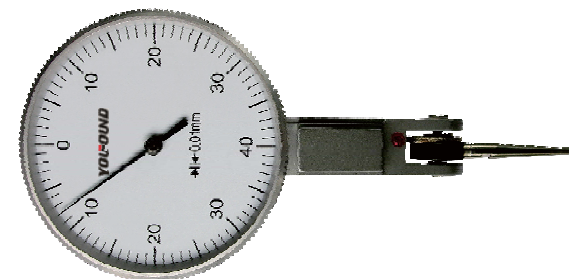

	Specification 规格	Dial Diam 表圈直径	QTY/CTN 装箱数量	N. W. /G. W. 净重/毛重(kg)	Meas(cm) 外箱尺寸
B0413-3280	0-0.8mm*0.01	32mm	50	7/8	34*22*20
B0413-3880	0-0.8mm*0.001	38mm	50	9/11	42*34*32
B0425-3203	0-0.03in*0.0005	1.26in	50	9/11	42*34*32
B0425-3803	0-0.03in*0.0005	1.5in	50	9/11	42*34*32
B0412-3220	0-0.2mm*0.002	32mm	50	9/11	42*34*32
B0412-4020	0-0.2mm*0.002	40mm	50	11/13	58*34*32
B0424-32008	0-0.008mm*0.0001	1.26in	50	11/13	58*34*32
B0424-32008	0-0.008mm*0.0001	1.57in	50	11/13	58*34*32

● **ELECTRONIC DIGITAL DIAL INDICATORS**

数显百分表



	Specification 规格	MPE 最大允许误差	QTY/CTN 装箱数量	N. W. /G. W. 净重/毛重 (kg)	Meas(cm) 外箱尺寸
B0233-5601	0-10mm*0.01 /0-0.5in*0.0005	±0.02mm/0.001in	50	9/11	47*30*22
B0233-5625	0-25mm*0.01 /0-1in*0.0005	±0.03mm/0.0015in	50	9/11	47*30*22

● **ELECTRONIC MICRON DIAL INDICATORS**

数显千分表



	Specification 规格	MPE 最大允许误差	QTY/CTN 装箱数量	N. W. /G. W. 净重/毛重 (kg)	Meas(cm) 外箱尺寸
B0231-6406	0-6mm*0.001 /0-0.2in*0.00005	±0.006mm /0.00025in	50	9/11	47*30*22

● **THICKNESS GAUGE**

厚度规



B0817-4010

● **Features 特性**

- Resolution:0.05mm or 0.1mm  
分辨率: 0.05mm或0.1mm
- Muilt-Test head  
多种测头形式

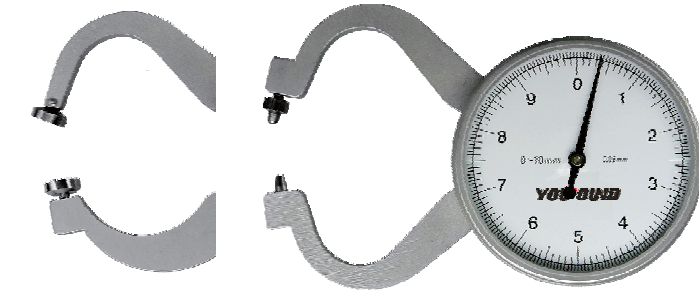

B0818-5010

● **THICKNESS GAUGE**

厚度规



K341-2125

● **Features 特性**

- Range:0-25mm/0-1in  
测量范围: 0-25mm/0-1in
- Specification: 0-150mm\*0.01/0-6in\*0.0005  
规格: 0-150mm\*0.01/0-6in\*0.0005
- Resolution:0.01mm/0.0005in  
分辨率: 0.01mm/0.0005in
- MPE=30μm  
最大允许误差: 30μm
- Zero setting at any position  
任意位置置零
- Max moving speed 1.5m/s  
最大响应速度1.5m/s
- Metric/Inch system interchange, with HOLD Function  
公英制转换, 带数据保持功能
- Throat Depth:250mm/10in  
喉深: 250mm/10in

● **HORIZONTAL SCALE UNIT**  
横式数显标尺

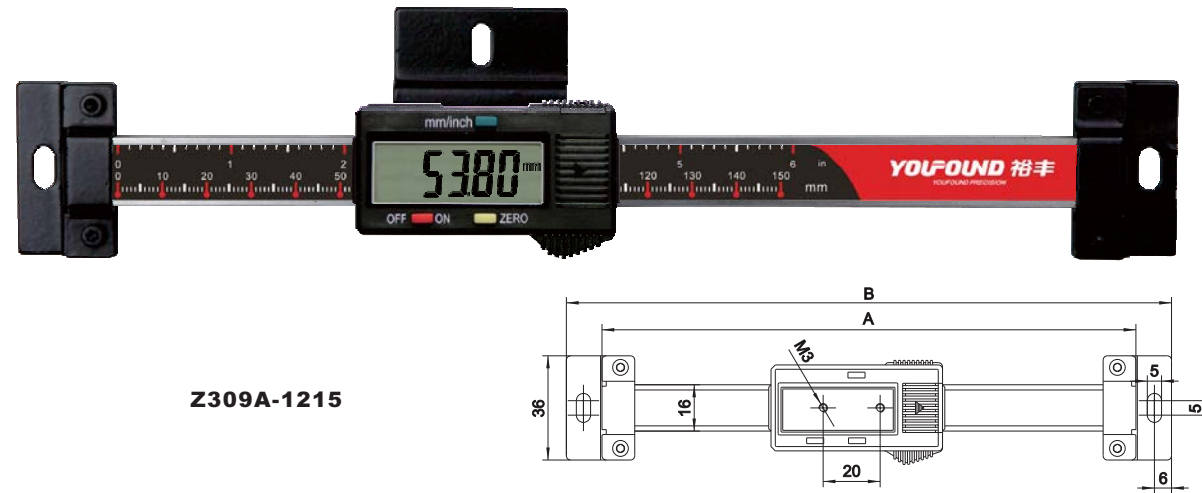

● **Features 特性**

- Max Range: 400mm (16in)  
最大测量范围: 400mm (16in)
- MPE=30μm ≤200mm; MPE=40μm > 200mm  
最大允许误差: 30 μm ≤200mm; 40 μm > 200mm
- Display Number Size 11mm  
显示数字高度11mm
- Zero setting at any position  
任意位置置零
- Max moving speed 1.5m/s  
最大响应速度1.5m/s
- Metric/Inch system interchange  
公英制转换
- Stainless Hardened  
不锈钢淬硬
- Manual Power ON/OFF  
手动断电

● **Optional features 可选功能**

- Mounting Plate for Slide  
尺框安装板
- USB Plug Base(Not USB Signal)  
USB连接座(非USB信号)
- Max moving speed 3m/s  
最大响应速度3m/s
- External Display  
外接显示器

	Specification 规格	QTY/CTN 装箱数量	N. W. /G. W. 净重/毛重 (kg)	Meas(cm) 外箱尺寸	A	B
Z309A-1210	0-100mm*0.01/0-4in*0.0005				185	209
Z309A-1215	0-150mm*0.01/0-4in*0.0005				235	259
Z309A-1220	0-200mm*0.01/0-8in*0.0005				286	310
Z309A-1230	0-300mm*0.01/0-12in*0.0005				420	444
Z309A-1240	0-400mm*0.01/0-16in*0.0005				570	594

● **HORIZONTAL SCALE UNIT**  
横式数显标尺

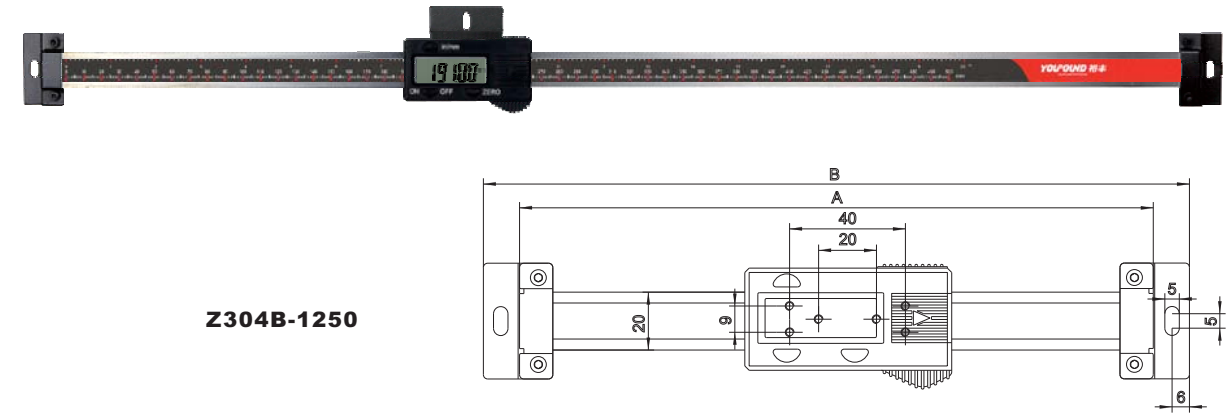

● **Features 特性**

- Max Range: 800mm (32in)  
最大测量范围: 800mm (32in)
- MPE=30μm ≤200mm; MPE=40μm > 200≤300mm; MPE=50μm > 300≤500mm; MPE=70μm > 500mm  
最大允许误差: 30 μm ≤200mm; 40 μm > 200≤300mm; 50 μm > 300≤500mm; 70 μm > 500mm
- Display Number Size 11mm  
显示数字高度11mm
- Zero setting at any position  
任意位置置零
- Max moving speed 1.5m/s  
最大响应速度1.5m/s
- Metric/Inch system interchange  
公英制转换
- Stainless Hardened  
不锈钢淬硬
- Manual Power ON/OFF  
手动断电

● **Optional features 可选功能**

- Mounting Plate for Slide  
尺框安装板
- USB Plug Base(Not USB Signal)  
USB连接座(非USB信号)
- Max moving speed 3m/s  
最大响应速度3m/s
- External Display  
外接显示器

	Specification 规格	QTY/CTN 装箱数量	N. W. /G. W. 净重/毛重 (kg)	Meas(cm) 外箱尺寸	A	B
Z304B-1245	0-450mm*0.01/0-18in*0.0005				570	594
Z304B-1250	0-500mm*0.01/0-20in*0.0005				610	634
Z304B-1260	0-600mm*0.01/0-24in*0.0005				715	739
Z304B-1280	0-800mm*0.01/0-32in*0.0005				915	939

● **VERTICAL SCALE UNIT**  
竖式数显标尺

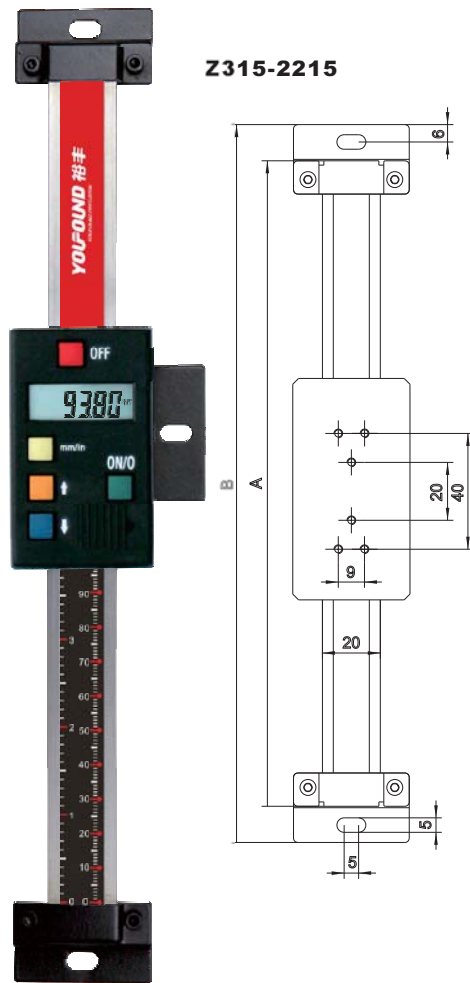

● **Features 特性** -----

- Max Range: 800mm (32in)  
最大测量范围: 800mm (32in)
- MPE=30μm ≤200mm; MPE=40μm > 200≤300mm;  
MPE=50μm > 300≤500mm; MPE=70μm > 500mm  
最大允许误差: 30μm ≤200mm; 40μm > 200≤300mm;  
50μm > 300≤500mm; 70μm > 500mm
- Display Number Size 11mm  
显示数字高度11mm
- Zero setting at any position  
任意位置置零
- Max moving speed 1.5m/s  
最大响应速度1.5m/s
- Metric/Inch system interchange  
公英制转换
- Stainless Hardened  
不锈钢淬硬
- Manual Power ON/OFF  
手动断电

● **Optional features 可选功能** -----

- Mounting Plate for Slide  
尺框安装板
- USB Plug Base(Not USB Signal)  
USB连接座(非USB信号)
- Max moving speed 3m/s  
最大响应速度3m/s
- External Display  
外接显示器

● **Optional Unit 可选款式** -----

Z314-



Z3106-



	Specification 规格	QTY/CTN 装箱数量	N. W. /G. W. 净重/毛重 (kg)	Meas(cm) 外箱尺寸	A	B
Z315-2210	0-100mm*0.01/0-4in*0.0005				220	244
Z315-2215	0-150mm*0.01/0-6in*0.0005				270	294
Z315-2220	0-200mm*0.01/0-8in*0.0005				320	344
Z315-2230	0-300mm*0.01/0-12in*0.0005				420	444
Z315-2240	0-400mm*0.01/0-16in*0.0005				570	594
Z315-2250	0-500mm*0.01/0-20in*0.0005				650	674
Z315-2260	0-600mm*0.01/0-24in*0.0005				750	774
Z315-2280	0-800mm*0.01/0-32in*0.0005				950	974

● **WIRELESS EXTERNAL DISPLAY**  
无线传输外接显示器

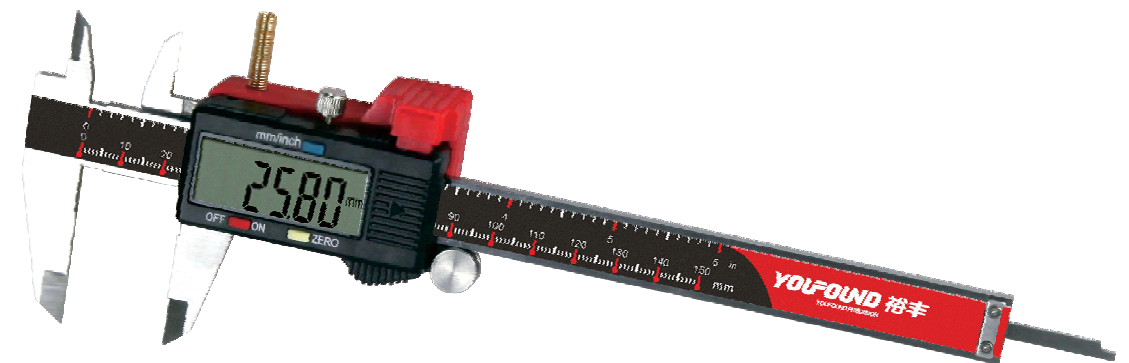
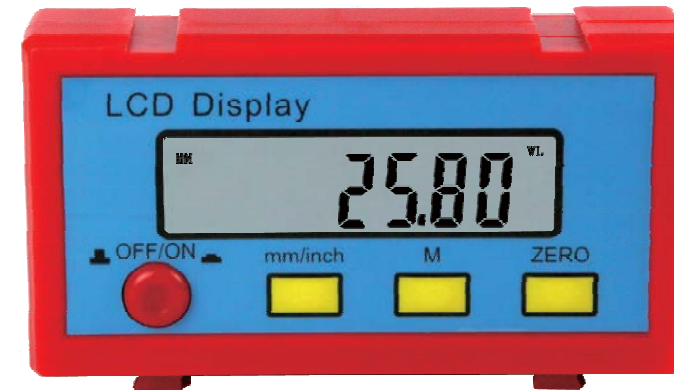

● **Features 特性** -----

- Display Range: -999.99mm/-40in~999.99mm/40in  
显示范围: -999.99mm/-40in~999.99mm/40in
- Resolution: 0.01mm/0.0005in  
分辨率: 0.01mm/0.0005in
- Transmission range: 50m/165feet  
最大传输距离: 50m/165feet
- MCU inside  
微处理器控制
- Single or continuous transmission  
单次或连续传输可选
- 433MHz ISM  
433MHz ISM工作频段
- Strong capacity of resisting disturbance  
抗干扰性强
- Auto sleep  
自动休眠

● **EXTERNAL DISPLAY WITH CABLE**  
有线传输外接显示器



● **Features 特性**

- Display Range: -999.99mm/-40in~999.99mm/40in  
显示范围: -999.99mm/-40in~999.99mm/40in
- Resolution: 0.01mm/0.0005in  
分辨率: 0.01mm/0.0005in
- Transmission range: 10m/33feet  
最大传输距离: 10m/33feet
- MCU inside  
微处理器控制
- Single or continuous transmission  
单次或连续传输可选
- USB Plug Base  
USB连接座
- Strong capacity of resisting disturbance  
抗干扰性强
- Auto sleep  
自动休眠

● **WIRELESS DATA ACQUISITION SYSTEM**  
无线数据传输采集系统



● **Features 特性**

- MCU Inside  
微处理器控制
- Transmission range: 50m/165feet  
最大传输距离: 50m/165feet
- 433MHz ISM  
433MHz ISM工作频段
- Strong capacity of resisting disturbance  
抗干扰性强
- Max.No. terminal 16  
最大连接16个终端
- Powerful software  
软件功能强大
- Save as EXCEL  
采集数据可存储为EXCEL文件
- Standard USB Connected to PC  
与计算机标准USB接口连接
- Can be setting the Tolerance, Automatically recognize qualified or not by PC  
可设置公差,并由计算机自动判别合格与否
- Status signal by LED at terminal  
终端LED信号灯指示测量状态
- Auto sleep and Auto connecting  
自动休眠,自动连接